

# SAUNA REFLECTION RIB GF

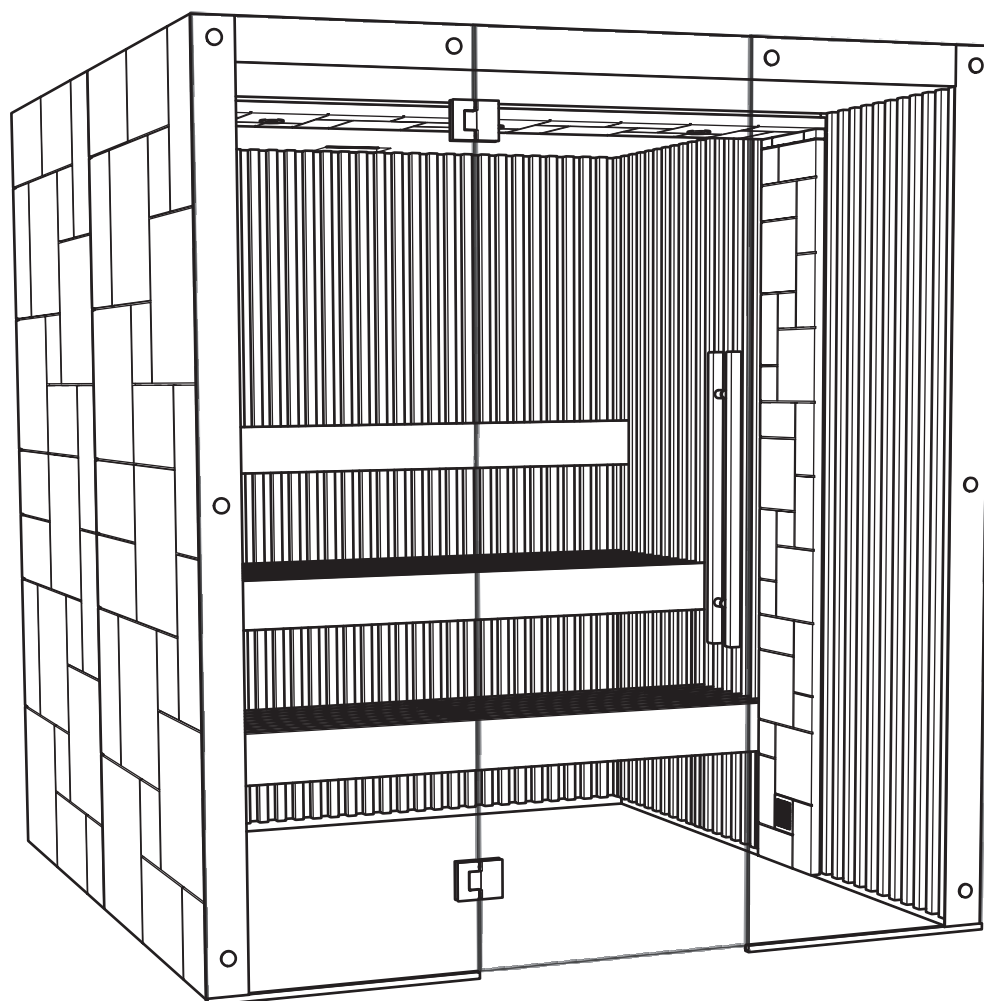

## Väggnummerering / Wall numbering

Väggarna är numrerade på sidan. Motsvarande siffra finns på layouten.

The walls are numbered on the side. The corresponding number is on the layout.

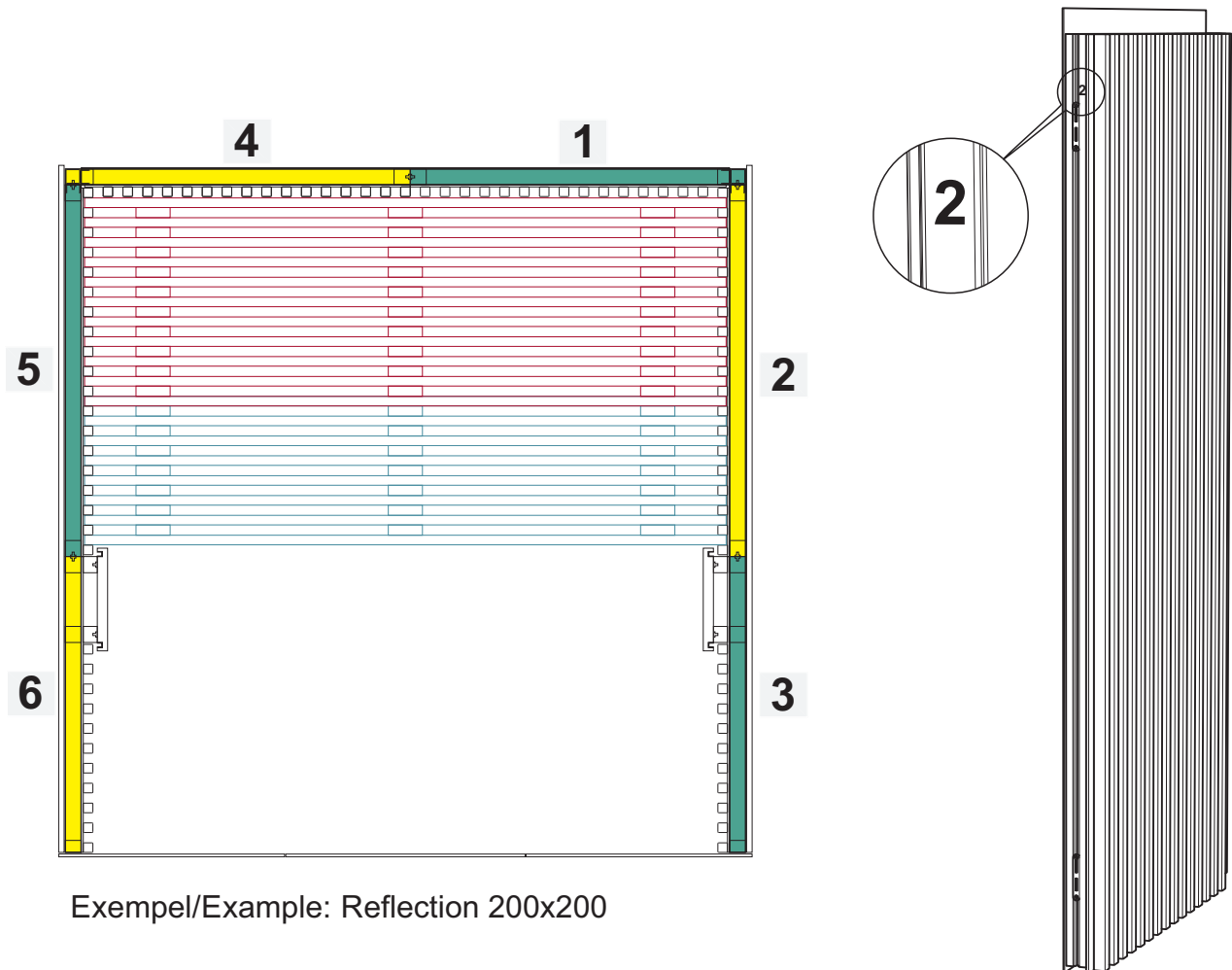

Exempel/Example: Reflection 200x200

## Tunga sektioner / Heavy sections

Väggar, tak och glas är tunga så det behövs två personer för att montera rummet.

The walls, ceiling and glass are heavy so two people are needed to assemble the room.

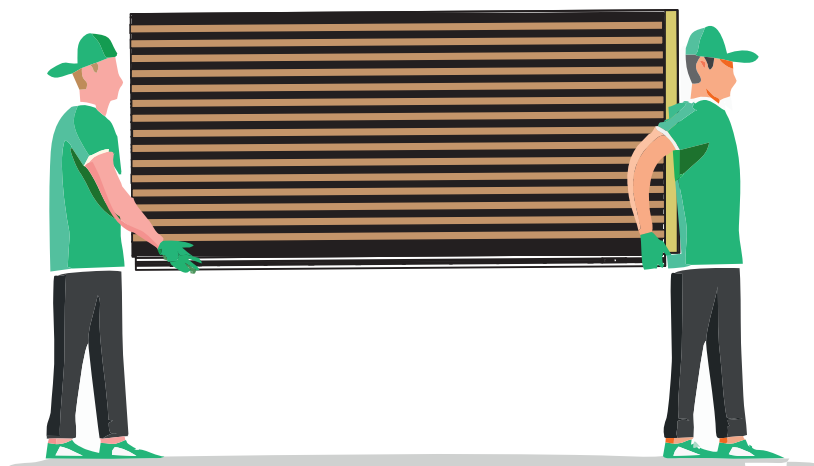

OBS! Endast golvstående bastuaggregat är tillåtet i ett Reflection.

ATTENTION! Only floor-standing sauna heaters are permitted in a Reflection.

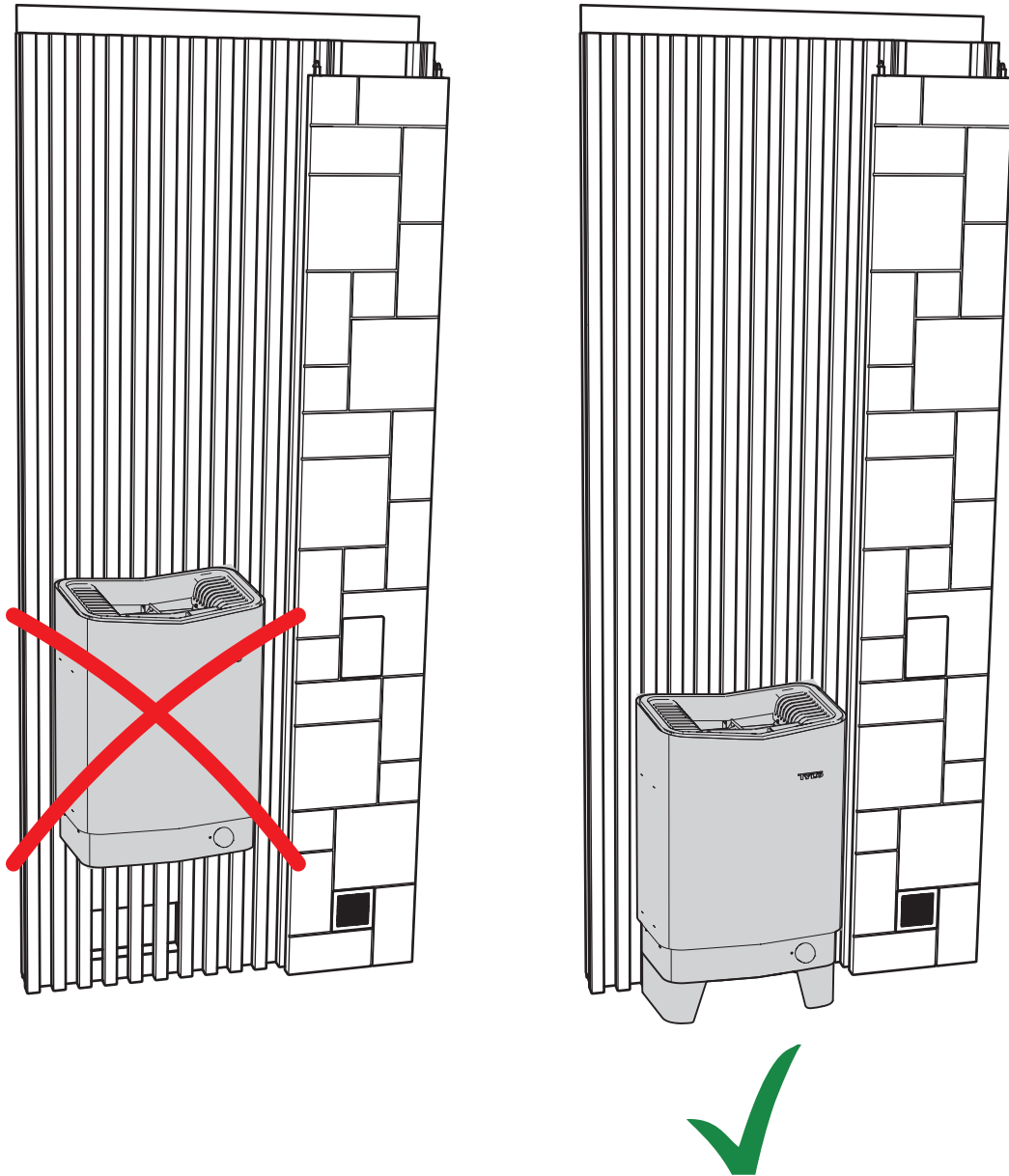

## Information

**Varning!** Glas - hanteras varsamt!  
**Warning!** Glass - handle with care!  
**Uwaga!** Ostrożnie- szkło!

Glasetts kanter aktas för slag och stötar.

The edges of the glass should be protected from knocks and impacts.

Krawędzie szyby powinny być chronione przed uderzeniami i wstrząsami.

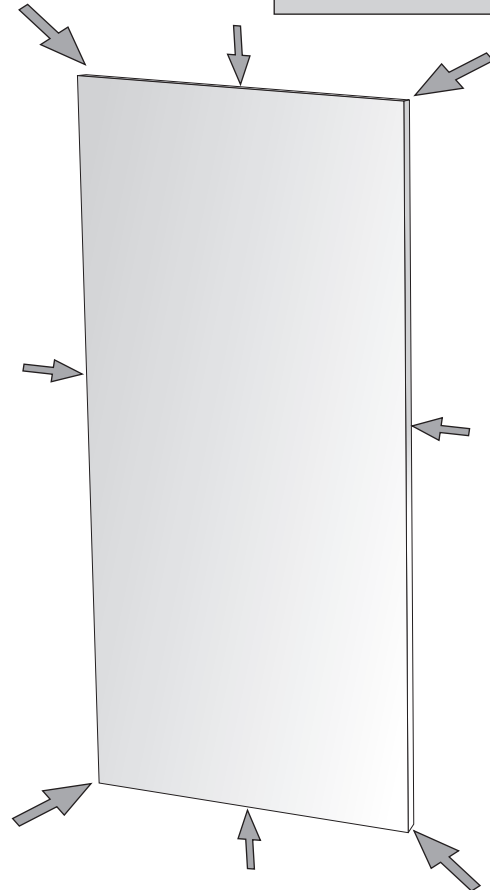

**Tips!**  
**Tip!**  
**Porada!**

**Rumsemballage**   **Room packaging**   **Opakowanie sauny**

Använd som skydd vid hantering av glasväggen.

Use as a protection when handling the glass wall.

Można wykorzystać jako ochronę podłogi podczas montażu sauny.



# Hantering och skötsel Valchromat Handling and care Valchromat

## Information

Rengöring av Valchromat: Blöt en trasa och torka.

Vid "svåra" fläckar (fettfläckar och dylikt): Gör roterande rörelser med medskickad slipkloss, borsta rent och torka med en blöt trasa.

Cleaning Valchromat: Wet a cloth and wipe. For "difficult" stains (grease stains and the like): Make rotating movements with the included sanding block, brush clean and dry with a wet cloth.

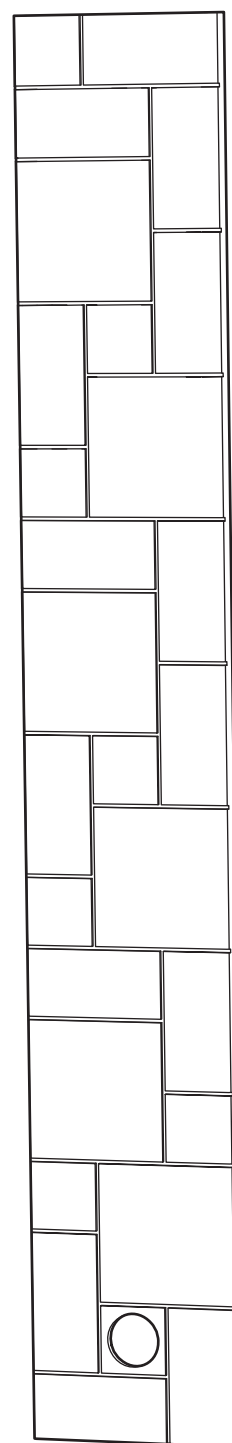
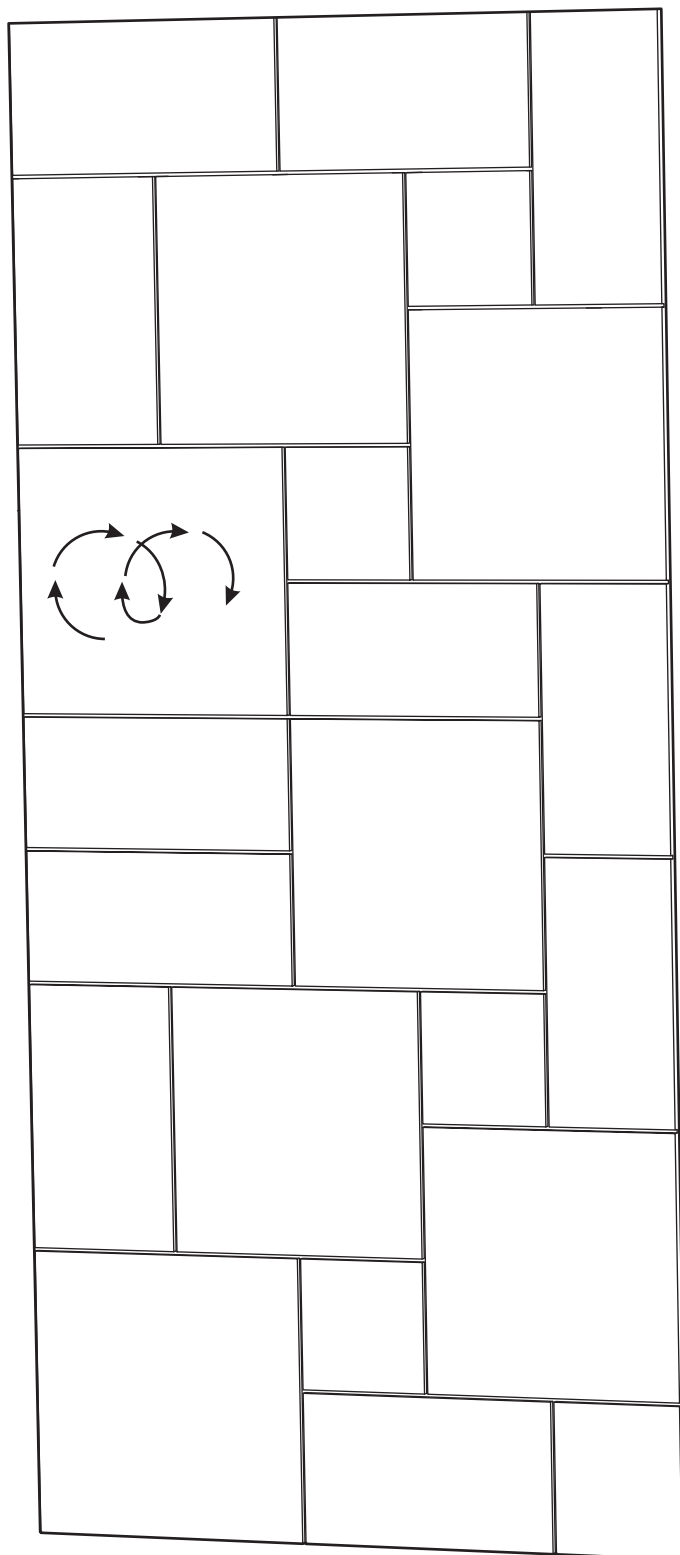
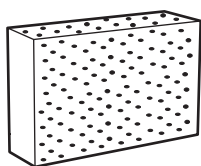

Detaljer och profiler som medföljer rummet  
 Details and profiles included with the room

Information

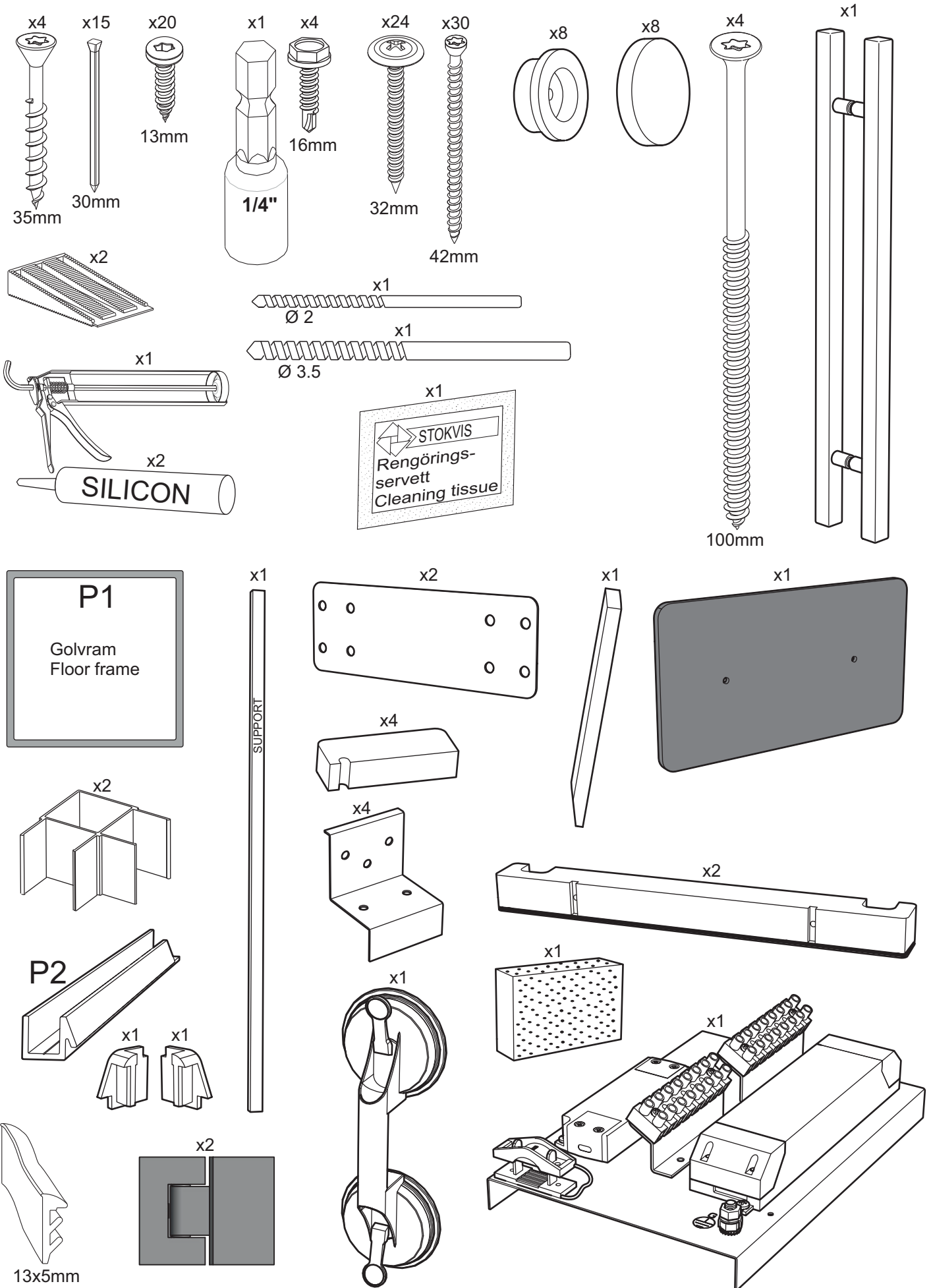

## Detaljer och profiler som medföljer rummet Details and profiles included with the room

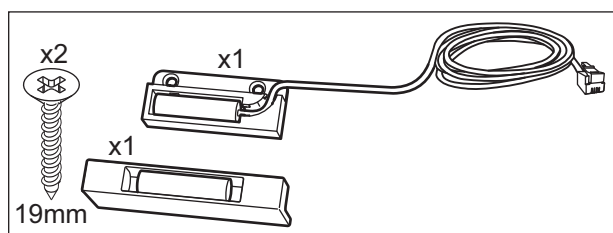
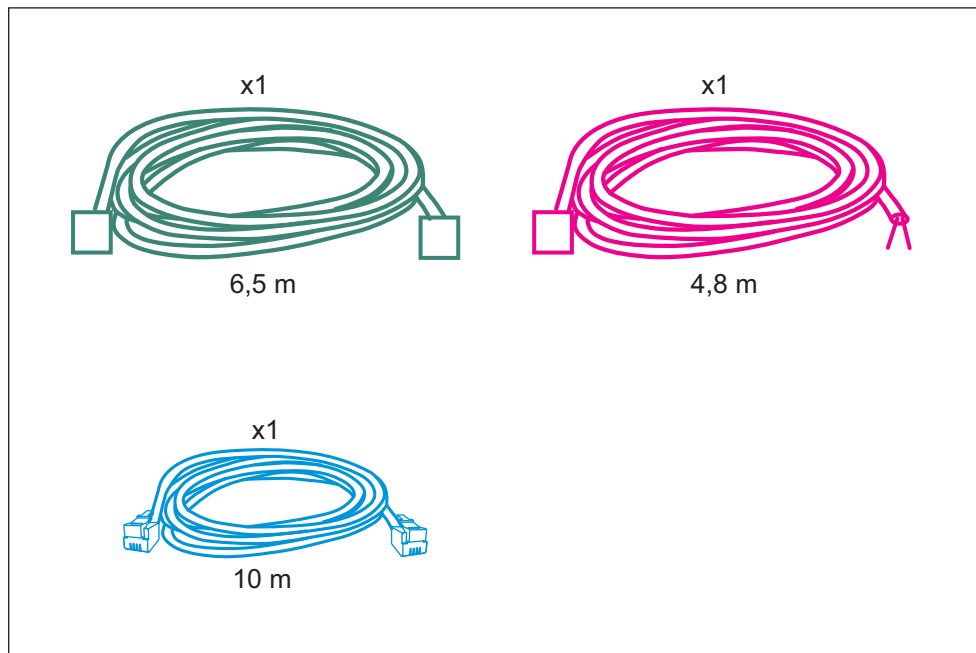

## Detaljer och profiler som medföljer inredningen Details and profiles included with the interior

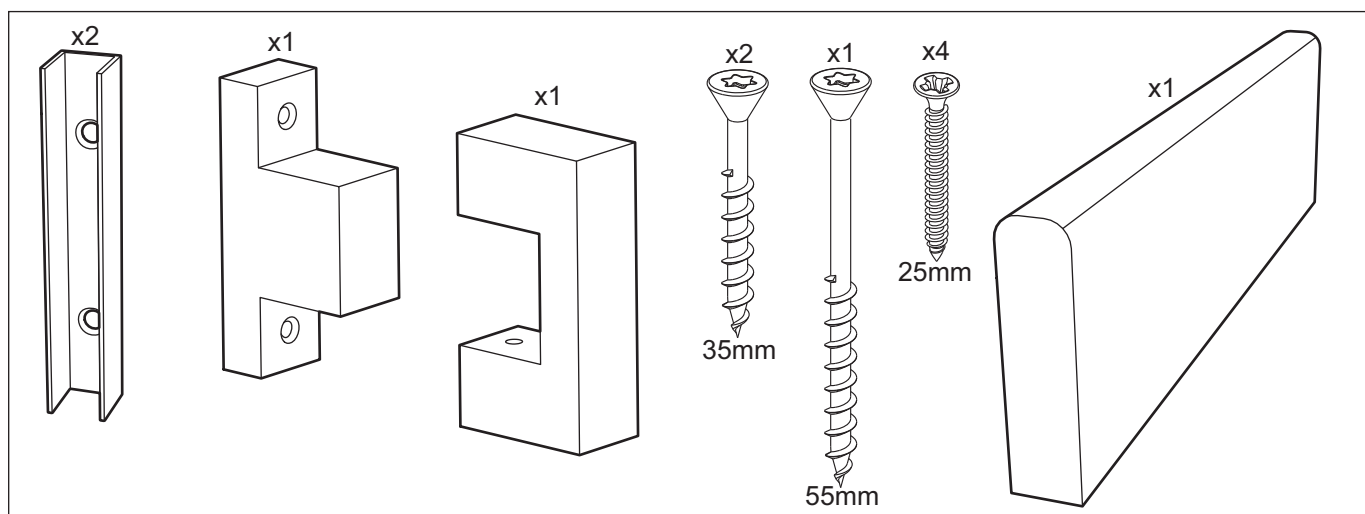

OBS! Denna instruktionen kan skilja sig jämfört med bastun som är levererad.  
 Rummet som monteras i denna manual är ett Sauna Reflection 200X200 GF.  
 Se layouten som medföljer rummet för mer detaljer.

Note! This instruction can differ from the room that is delivered.  
 The room that is mounted in this manual is a Sauna Reflection 200X200 GF.  
 See the layout that comes with the sauna room for details.

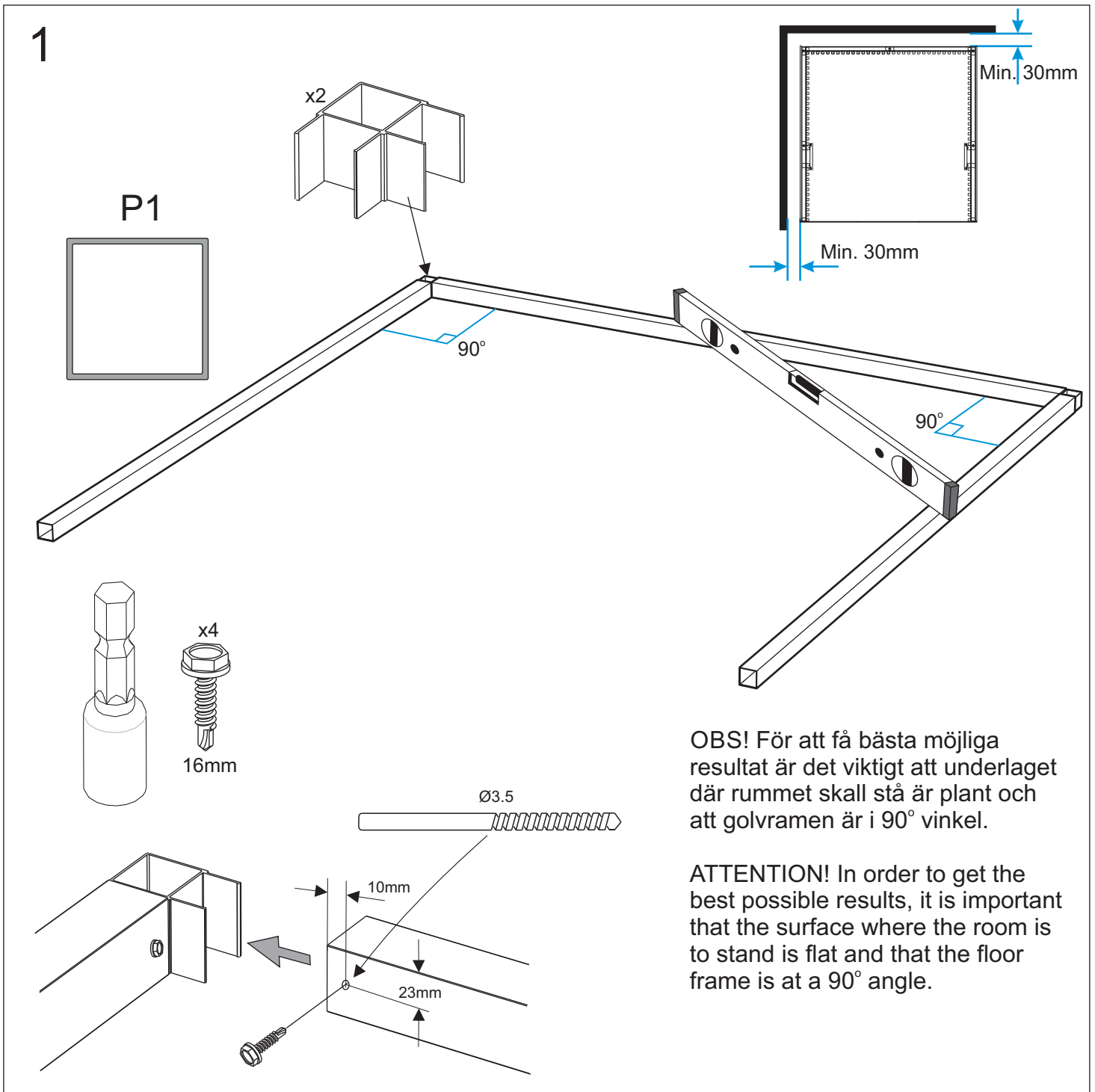

OBS! För att få bästa möjliga resultat är det viktigt att underlaget där rummet skall stå är plant och att golvråmen är i 90° vinkel.

ATTENTION! In order to get the best possible results, it is important that the surface where the room is to stand is flat and that the floor frame is at a 90° angle.

TIPS! För att hålla rätt mått på golvråmen, kapa en bräda i samma mått som den bakre golvråmen och lägg i fronten.

TIP! To keep the dimensions of the floor frame correct, cut a board to the same dimensions as the rear floor frame and insert it into the front.

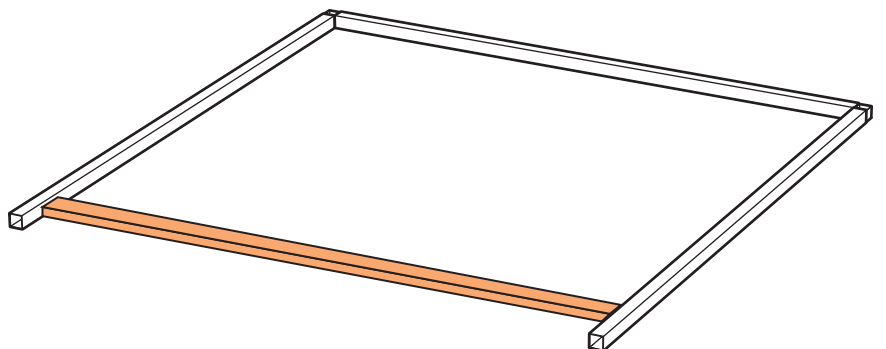



# 2

Välj sida för inluft/aggregatplacering. Skruva fast plattan på den aggregatsektion som inte ska användas.

Select side for exhaust air/heater placement. Screw the plate onto the heater section that is not to be used.

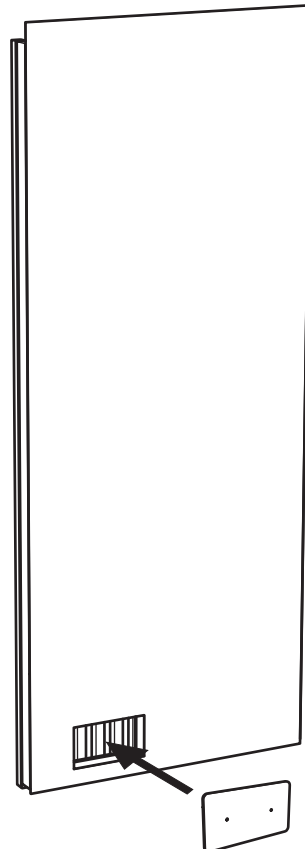
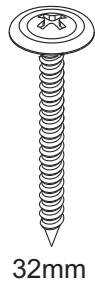
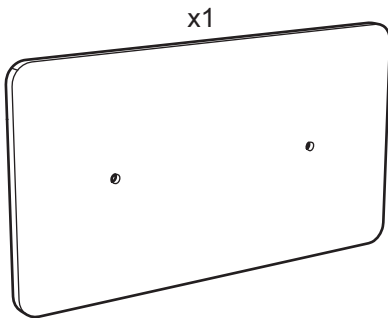
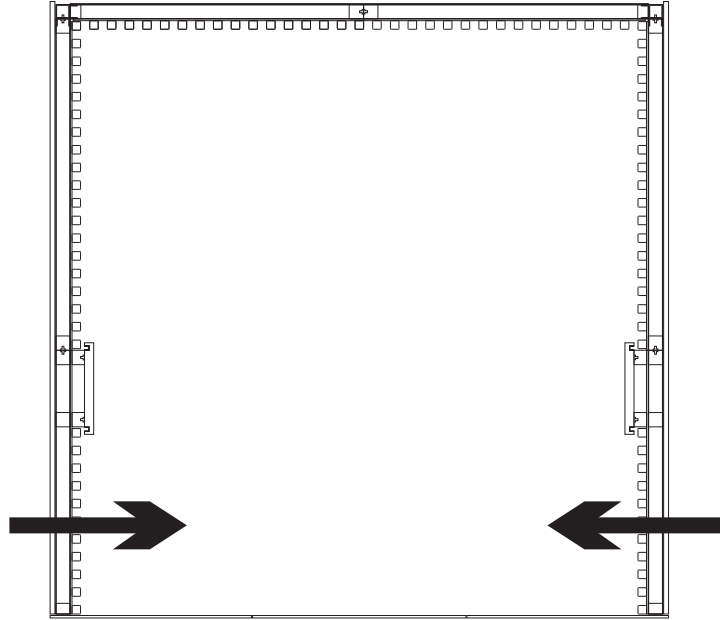

3

1

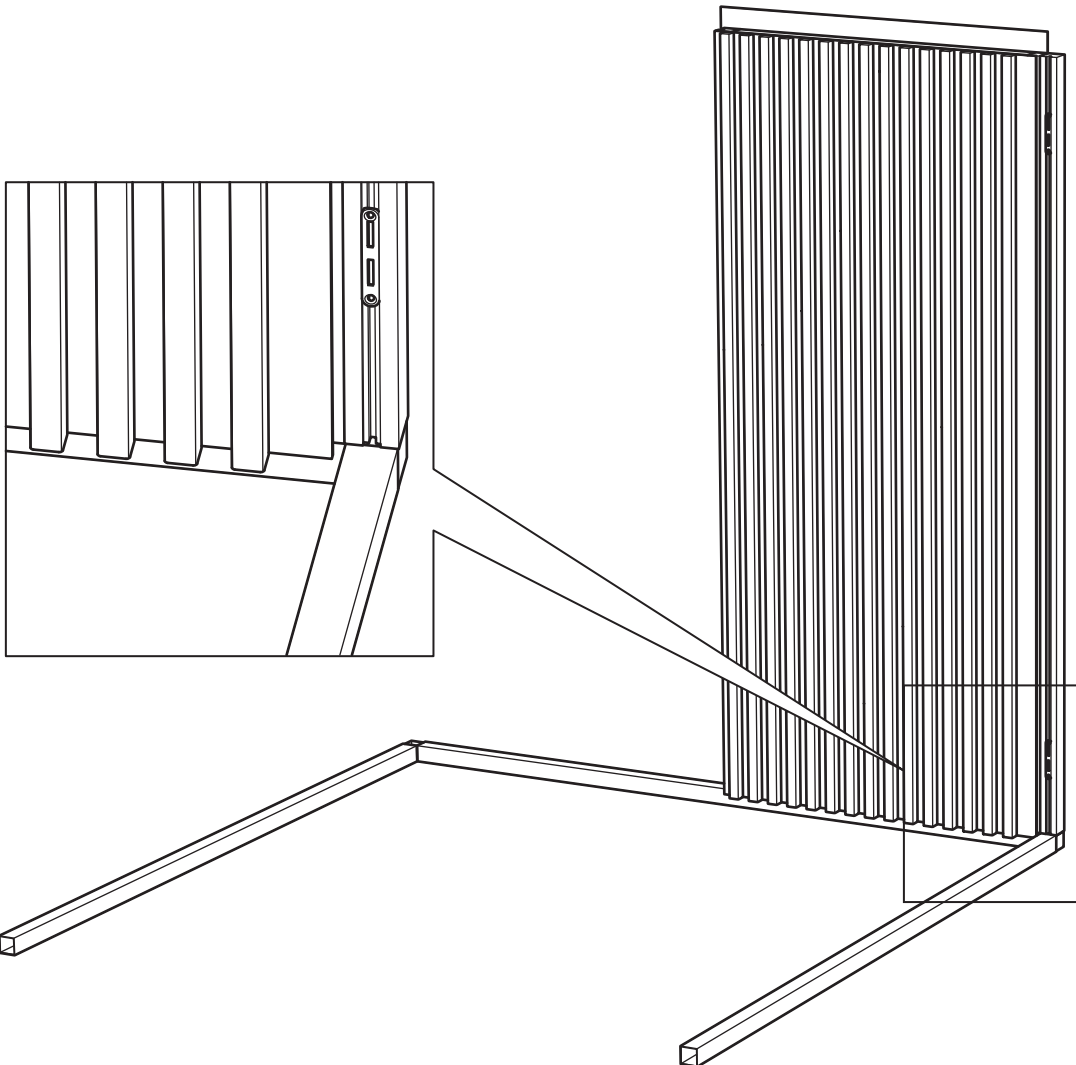
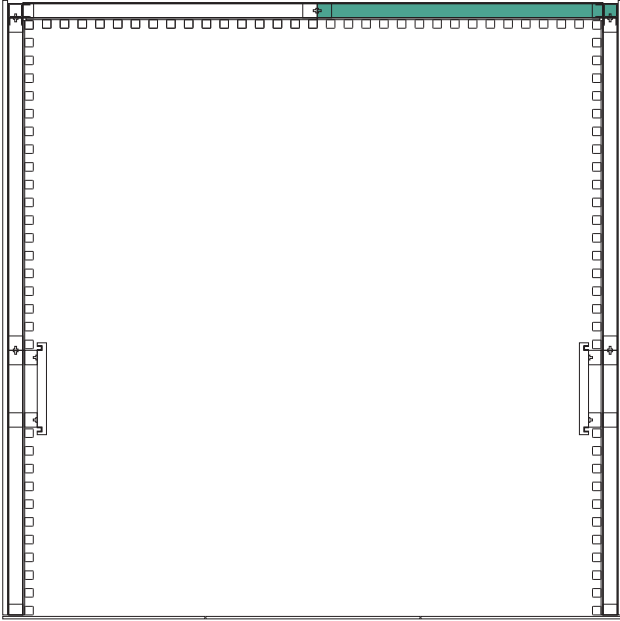

4

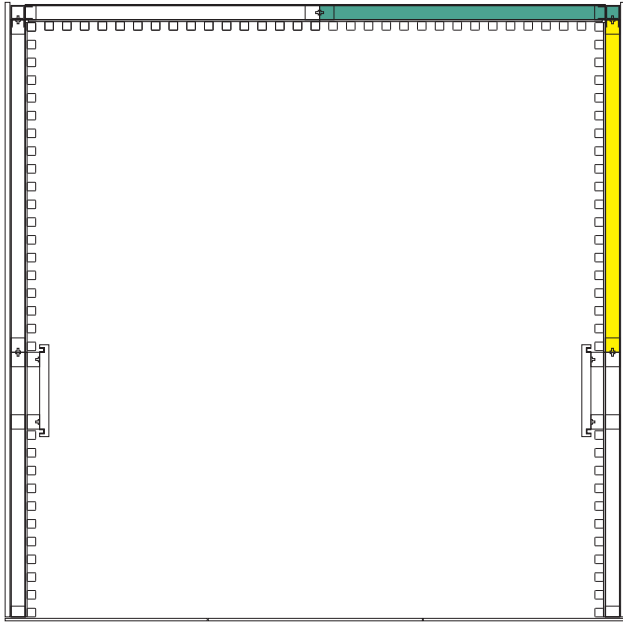

2

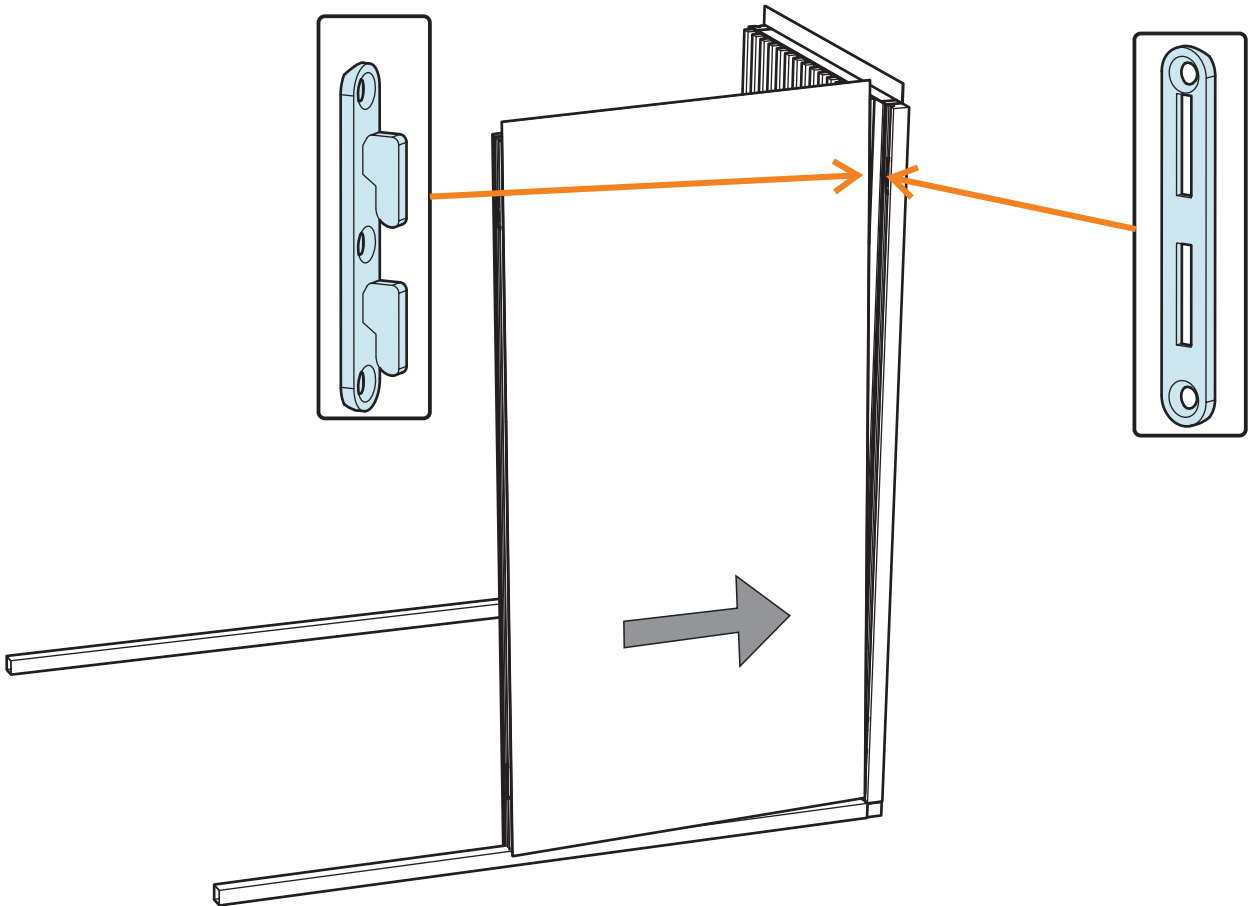
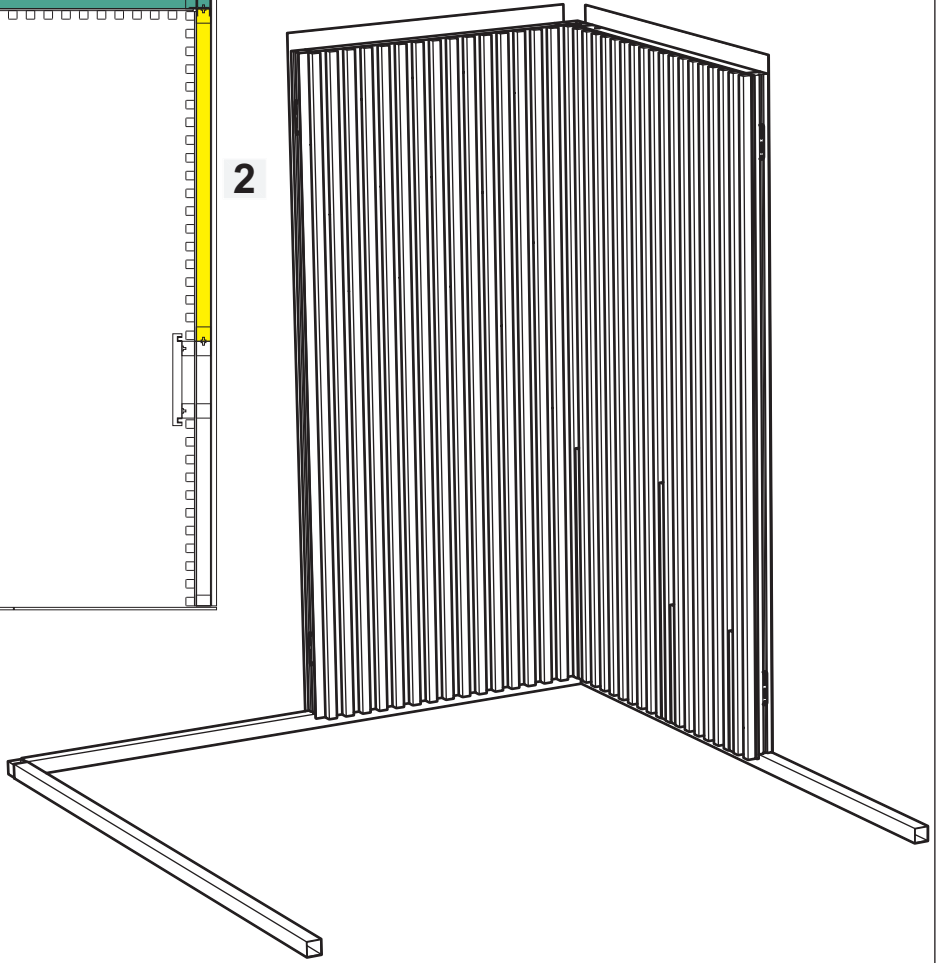

5

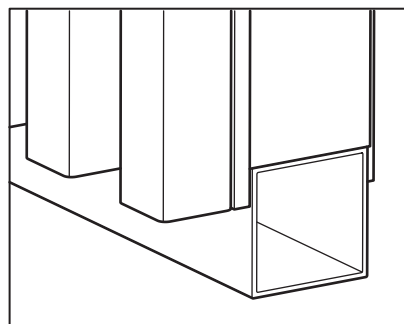
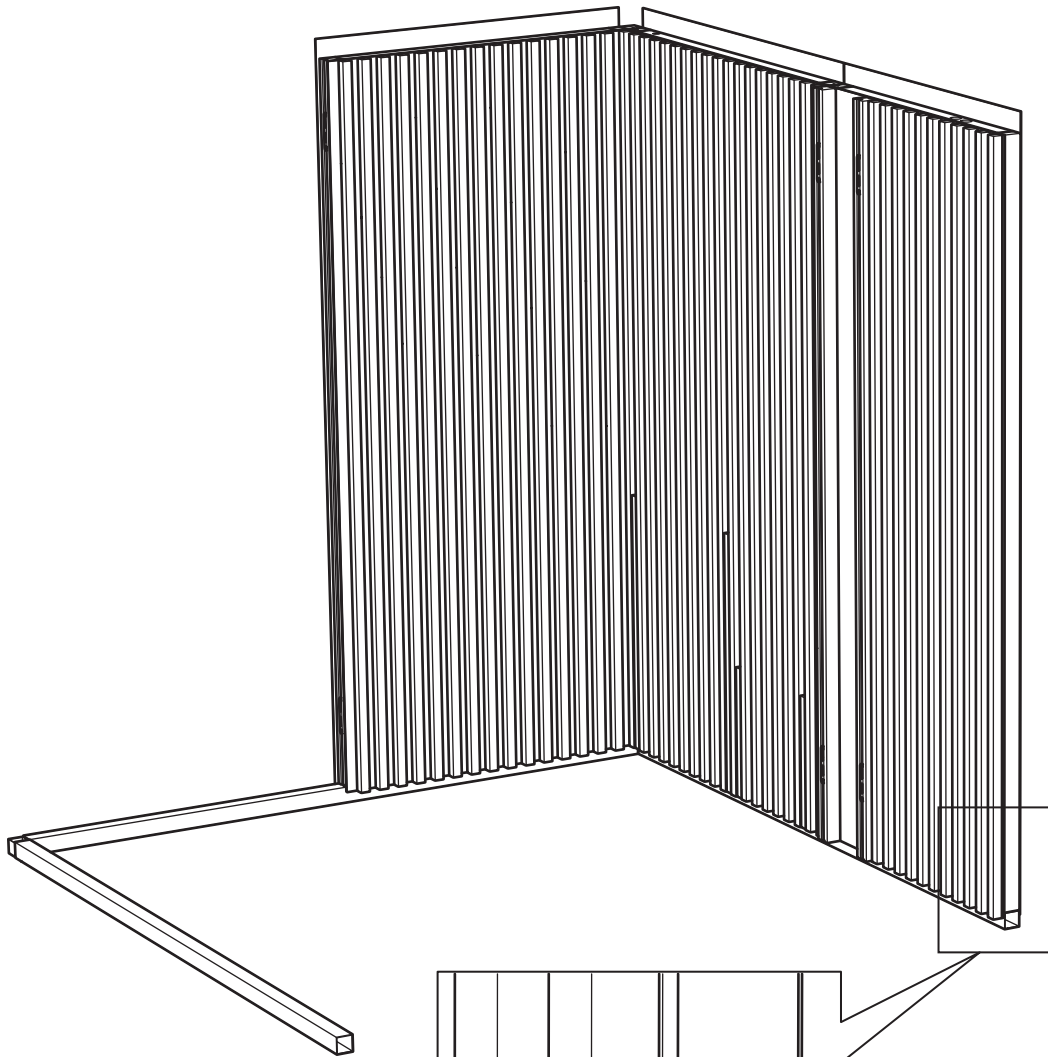
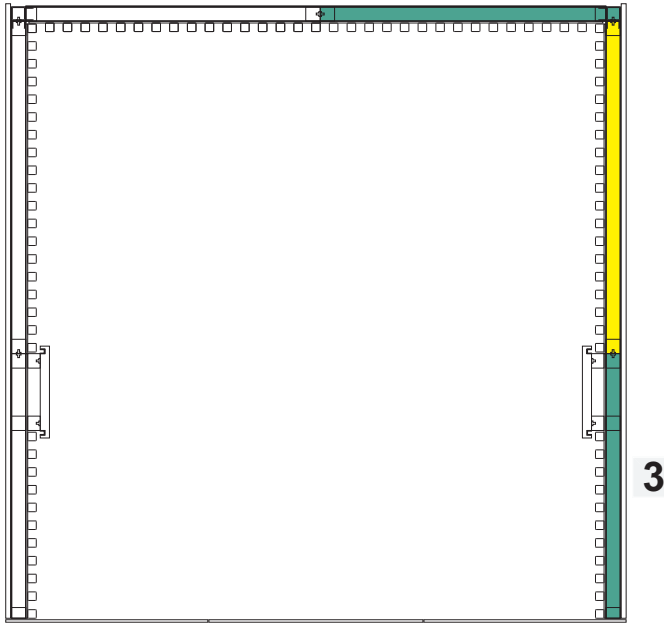

Väggen skall placeras kant i kant med golvransprofilen.

The wall must be placed edge to edge with the floor frame profile.

6

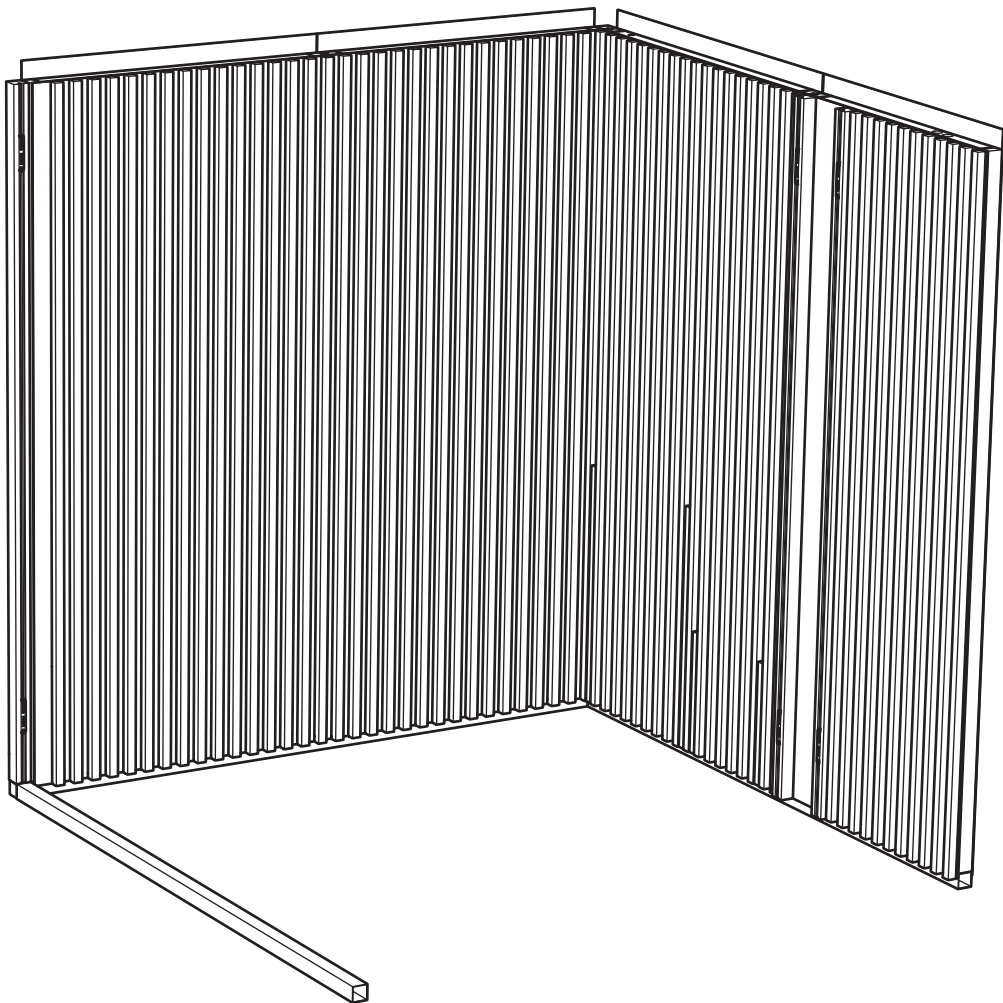
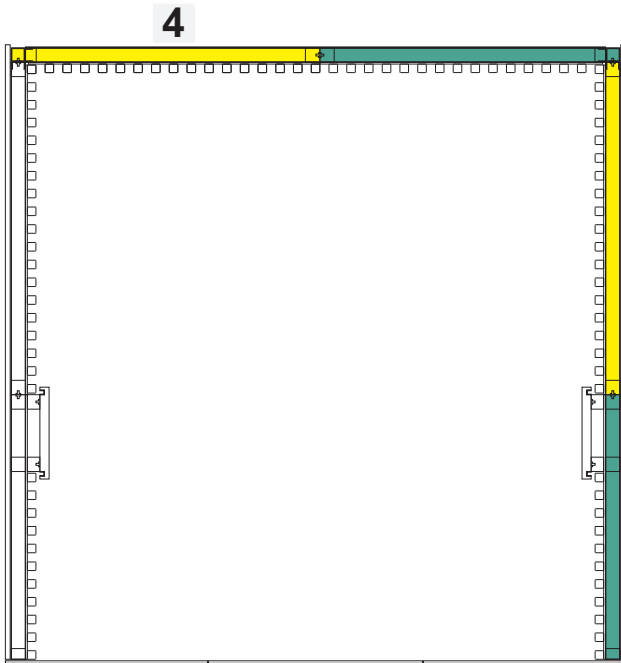

7

5

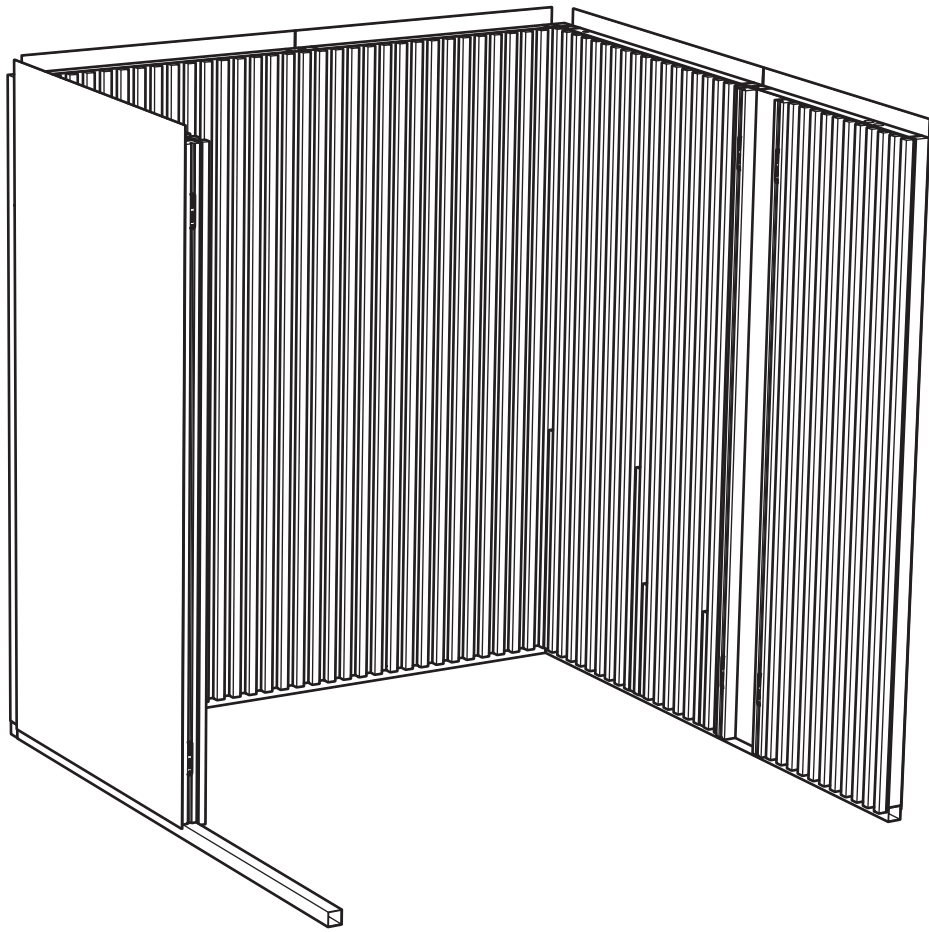
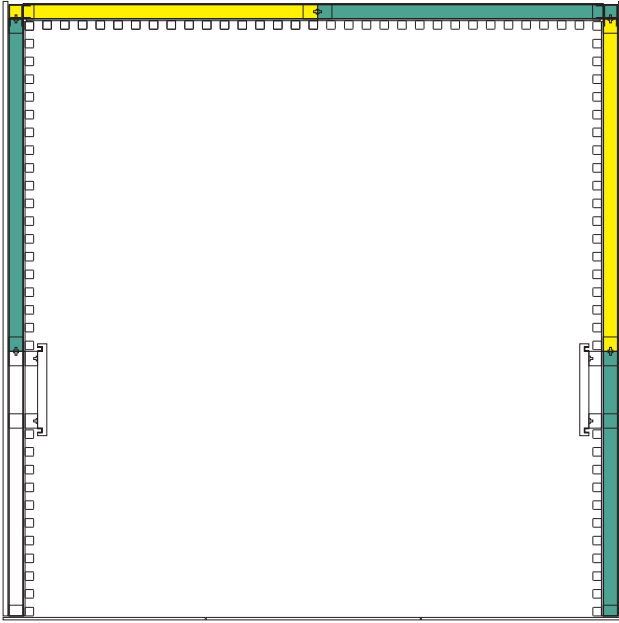

8

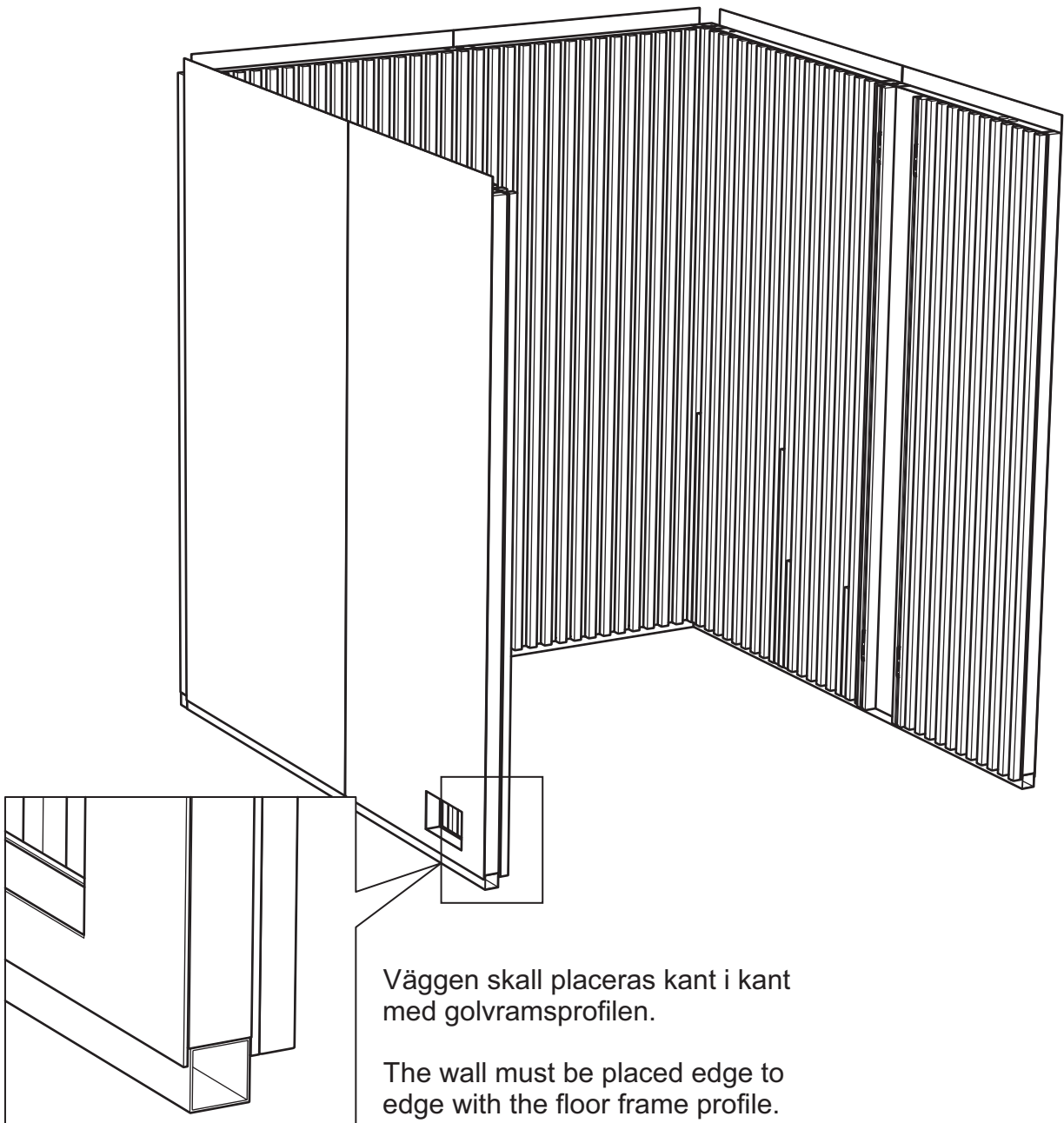
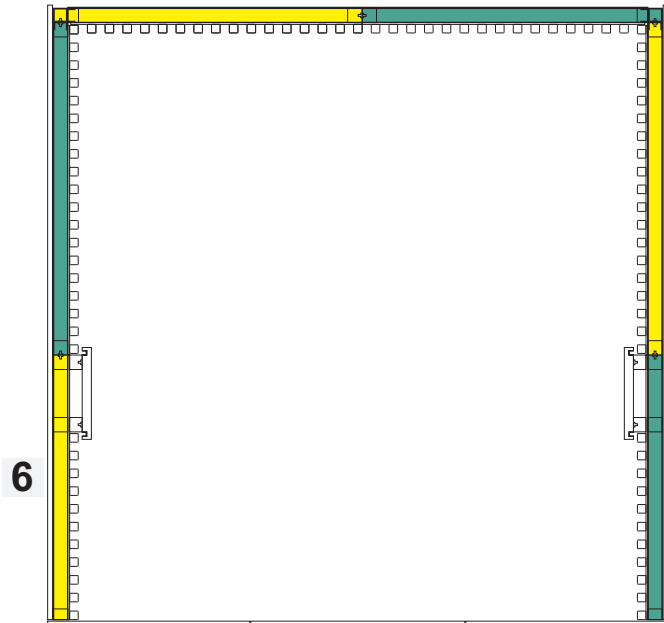

Väggen skall placeras kant i kant med golvransprofilen.

The wall must be placed edge to edge with the floor frame profile.

9

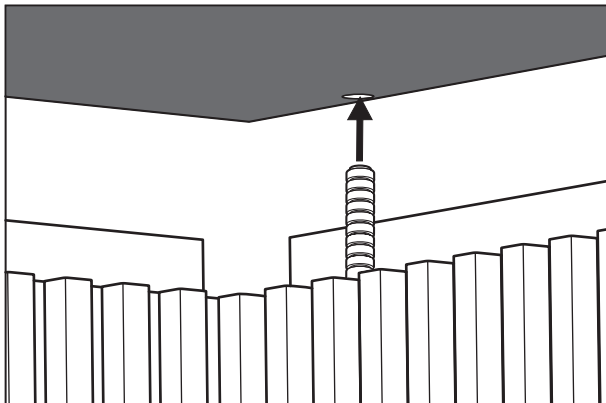
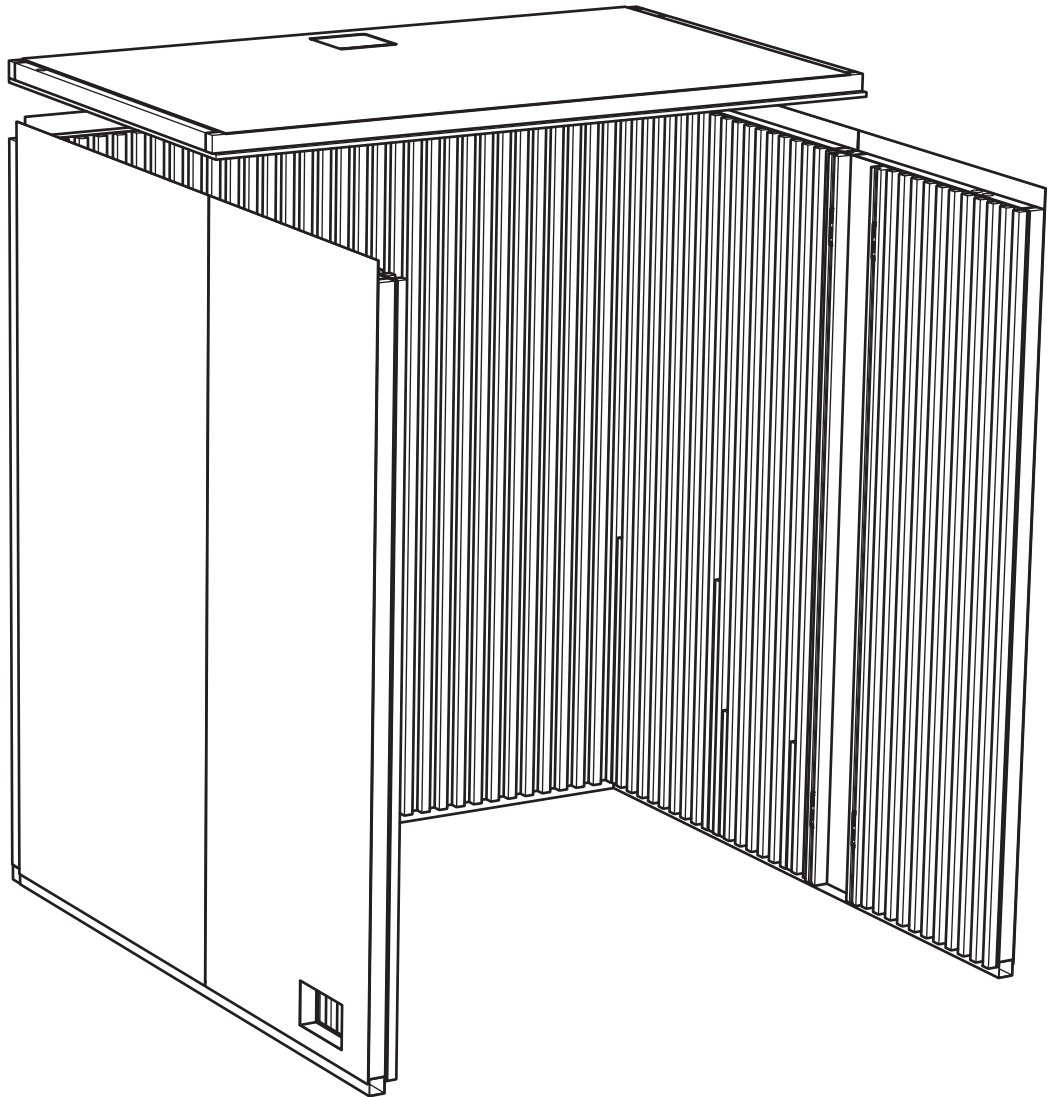

Se till att styra flexrören i de bakre sidoväggarna för belysning genom hålen i taket.

Be sure to route the flex pipes in the rear sidewalls for lighting through the holes in the ceiling.

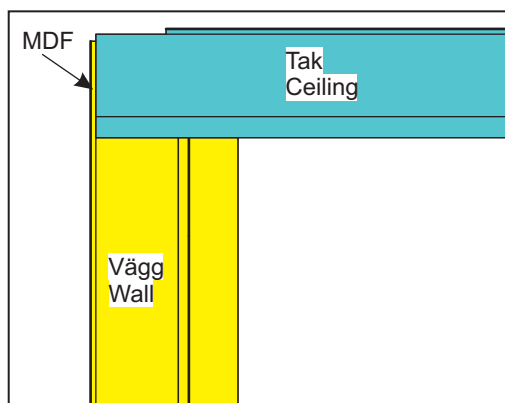

Taket ska ligga mot mdf:en som sitter på baksidan av väggarna.

The ceiling should lie against the mdf which is on the back of the walls.



10

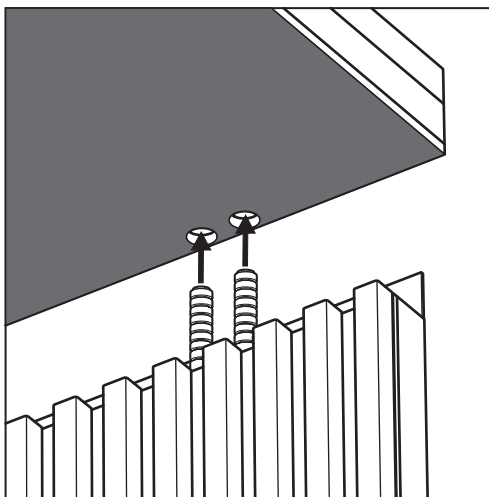
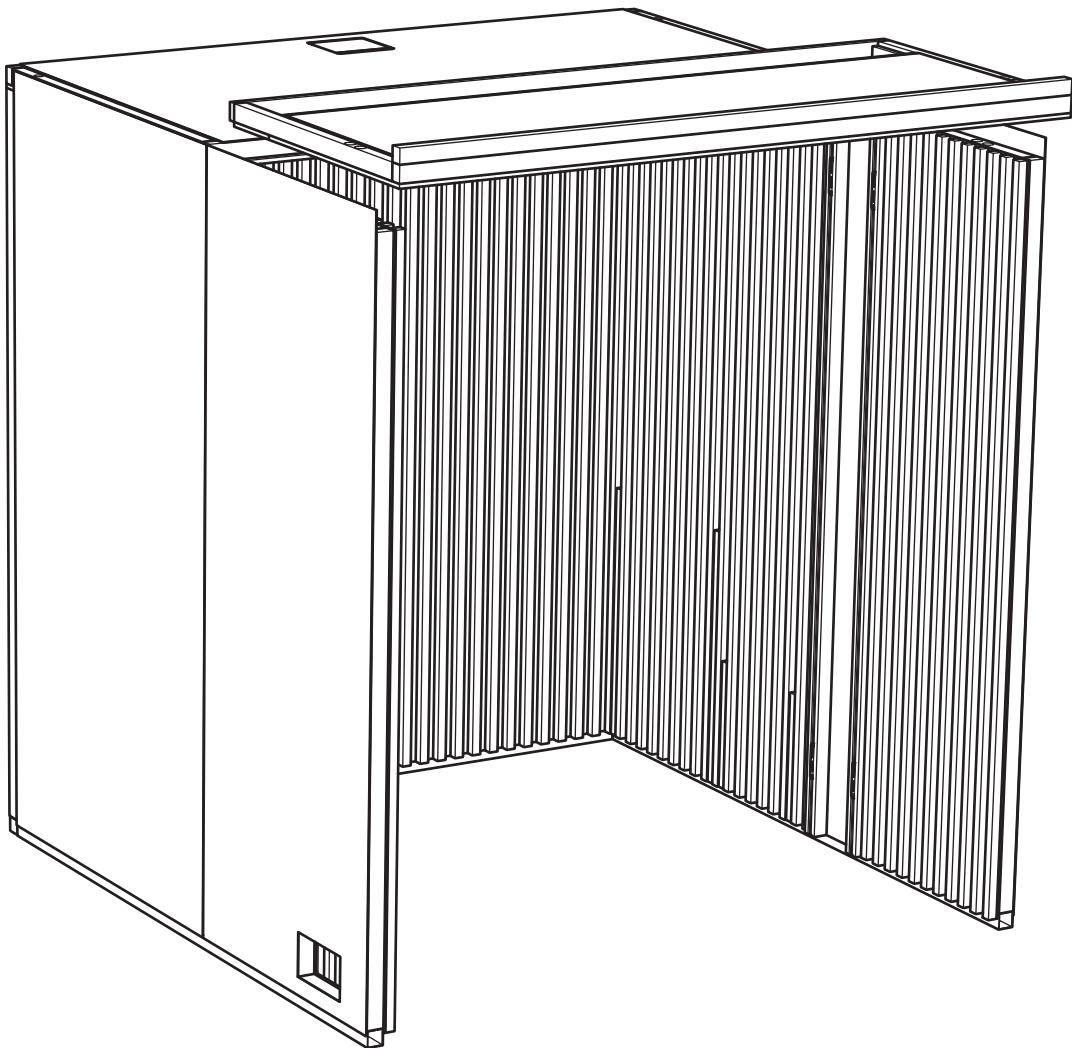

Se till att styra flexrören i de främre sidoväggarna för eldragning genom hålen i taket.

Be sure to route the flex pipes in the front side walls for wiring through the holes in the ceiling.

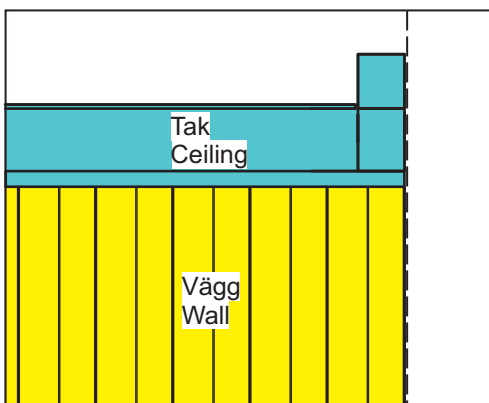

Lägg taket så att det linjerar med den främre väggen.

Place the roof so that it lines up with the front wall.

# 11

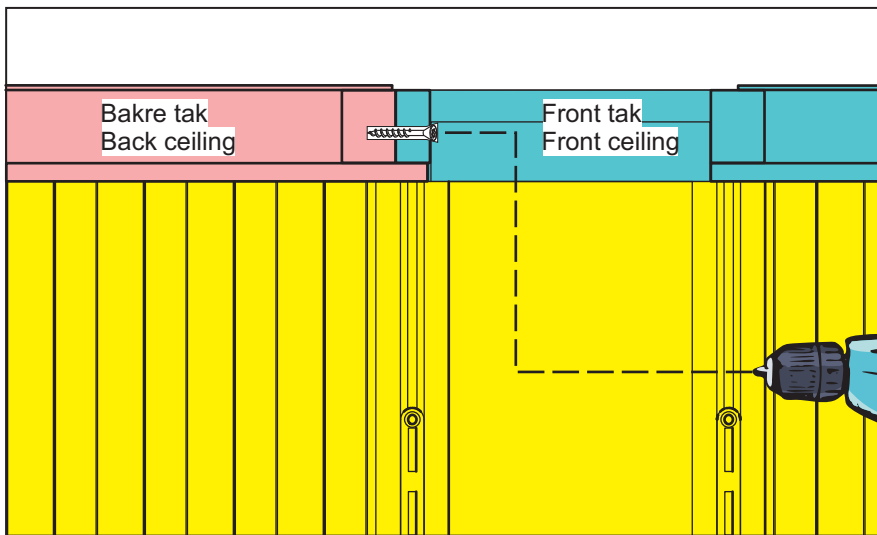
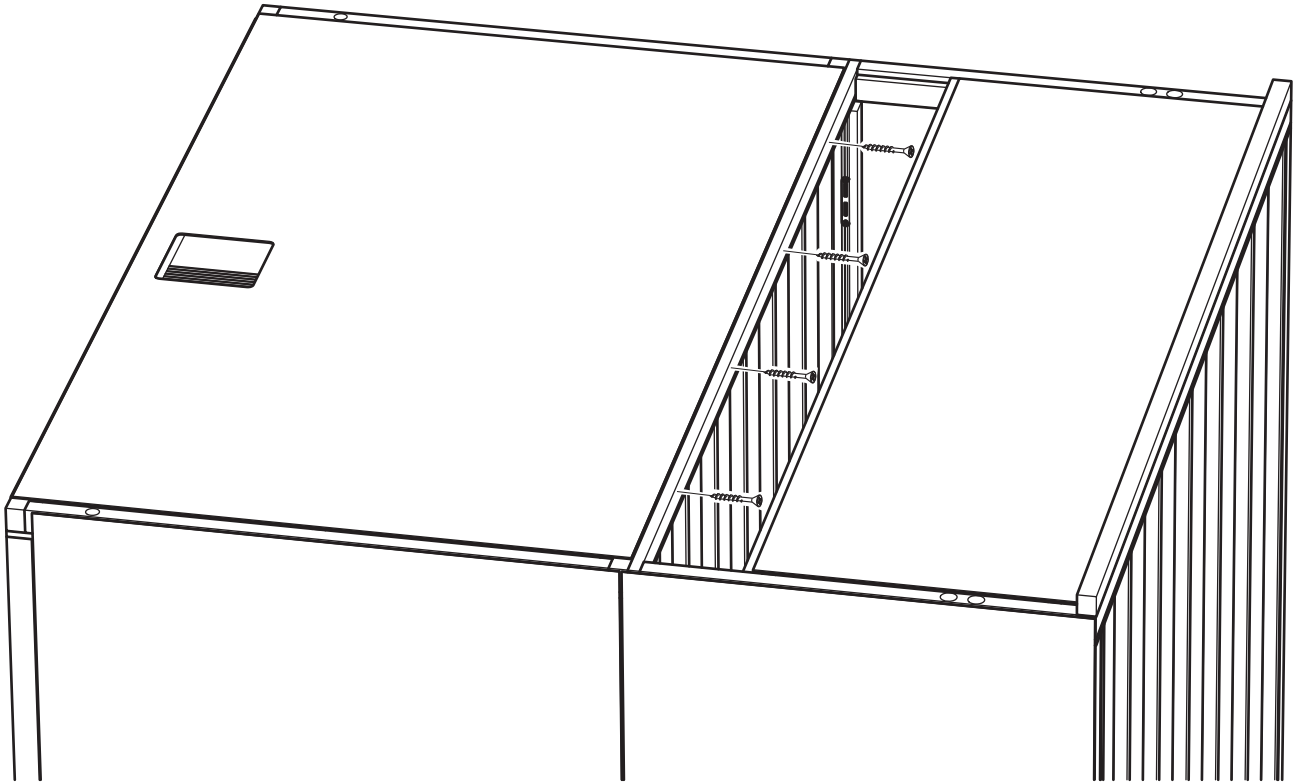
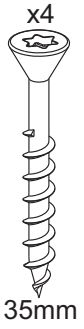

Borra hål och skruva ihop de båda taken i utrymmet för takportalen.

Drill holes and screw the two roofs together in the space for the ceiling portal.

12

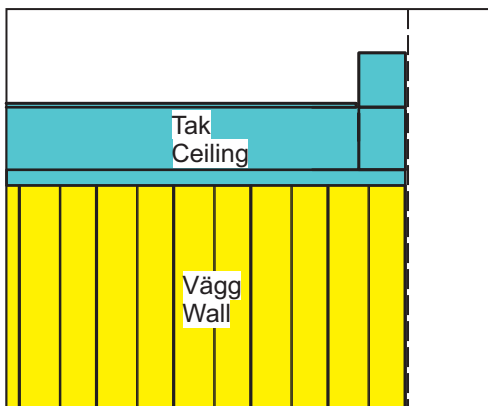
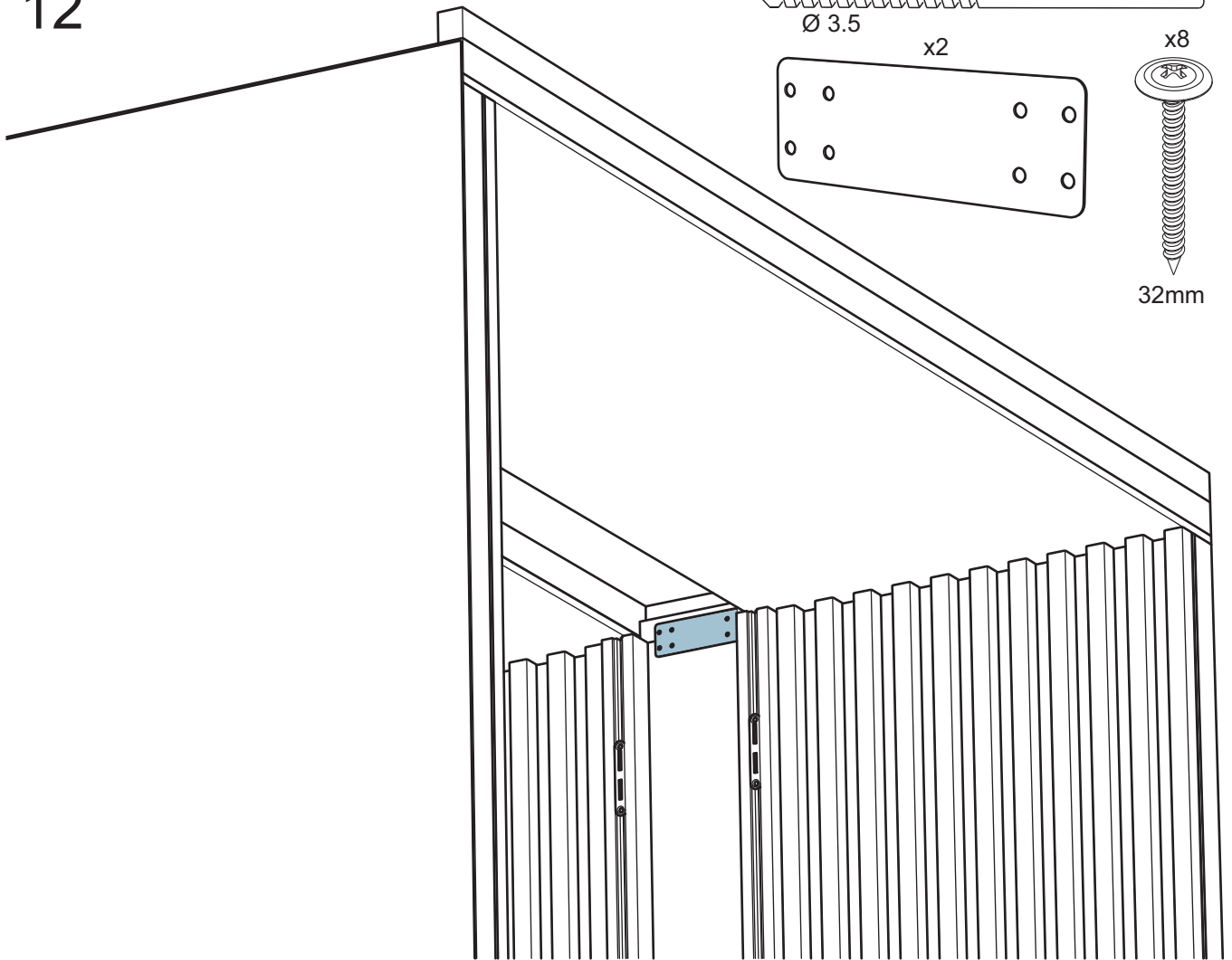
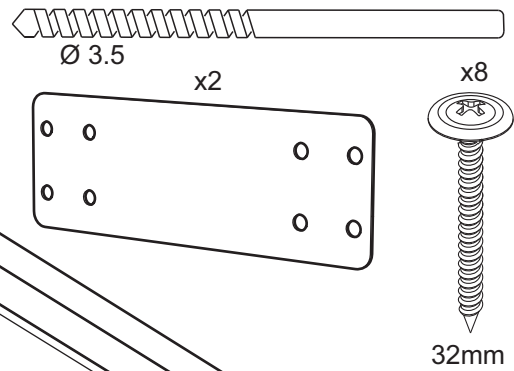

Kontrollera att främre tak och frontväggar linjerar med varandra.

Check that the front roof and front walls line up with each other.

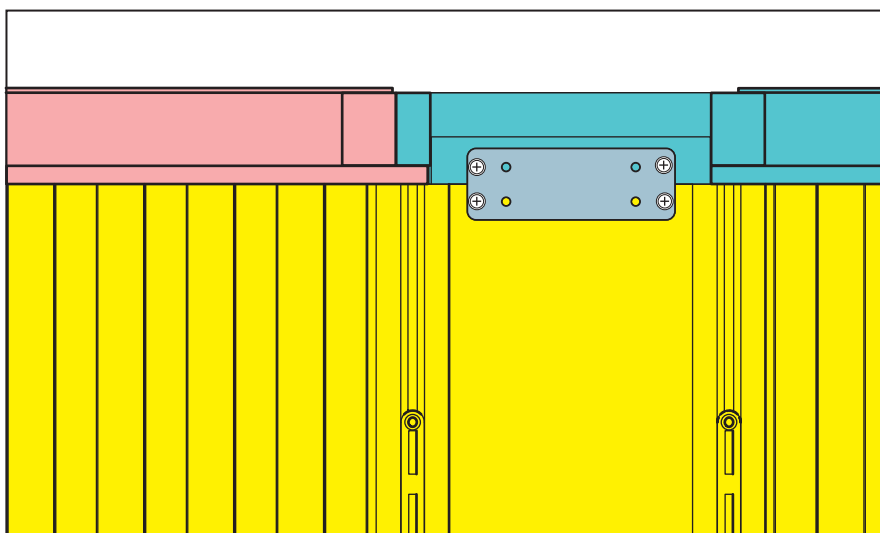

Skruva fast fästblecken mellan främre tak och vägg.

Screw the fastening plate between the front ceiling and wall.

13

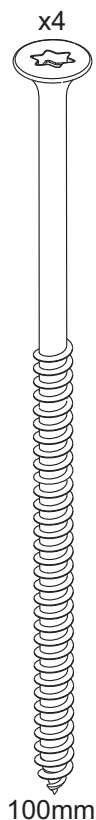

Skruva fast taken uppifrån i mån det finns plats

Screw the roofs from above if there is room

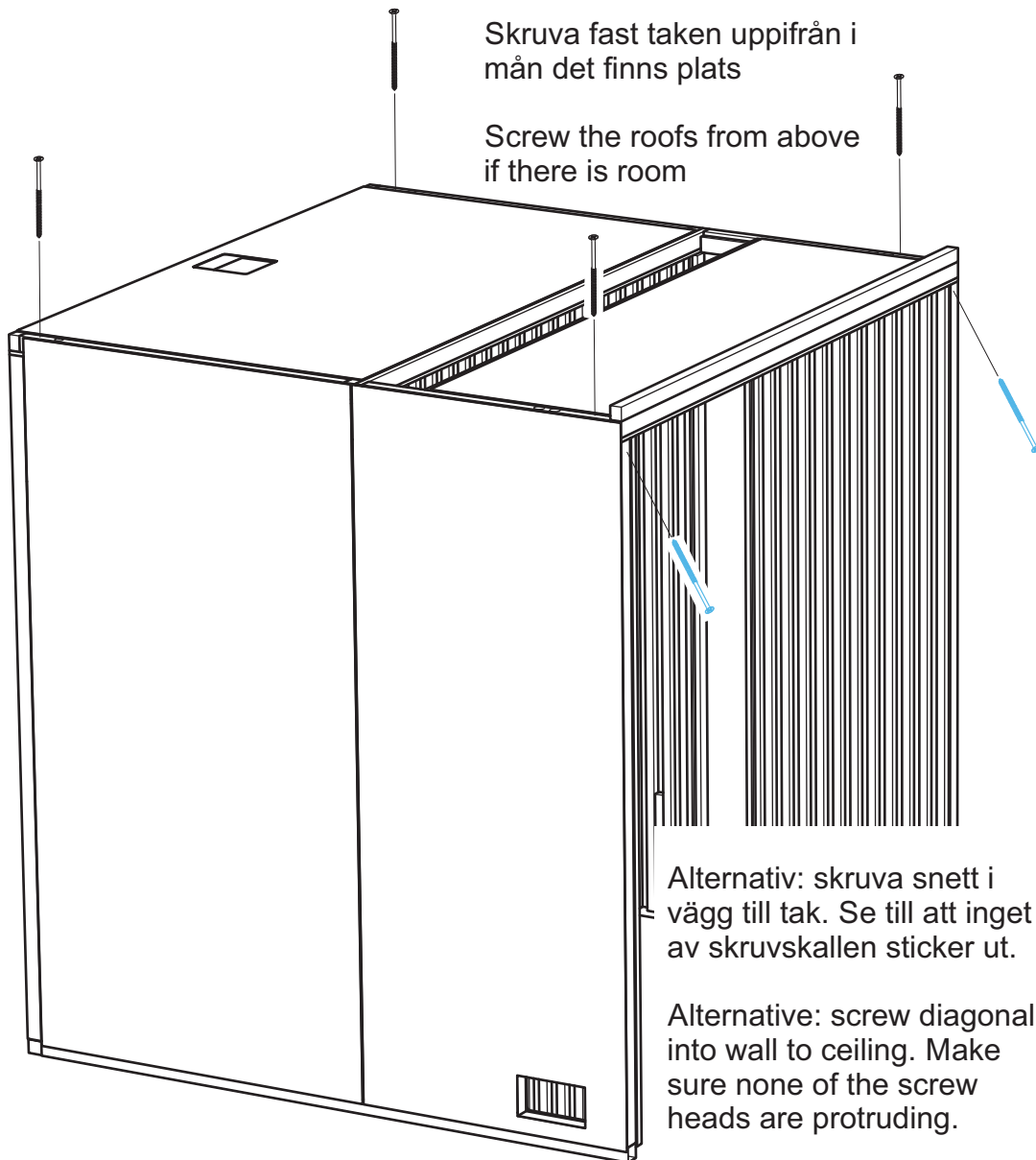

Alternativ: skruva snett i vägg till tak. Se till att inget av skruvskallen sticker ut.

Alternative: screw diagonally into wall to ceiling. Make sure none of the screw heads are protruding.

**Takportal med spotlights**  
**Ceiling portal with spotlights**

Koppla spotlightsen enligt schema på takportalen

Connect the spotlight according to the diagram on the ceiling portal

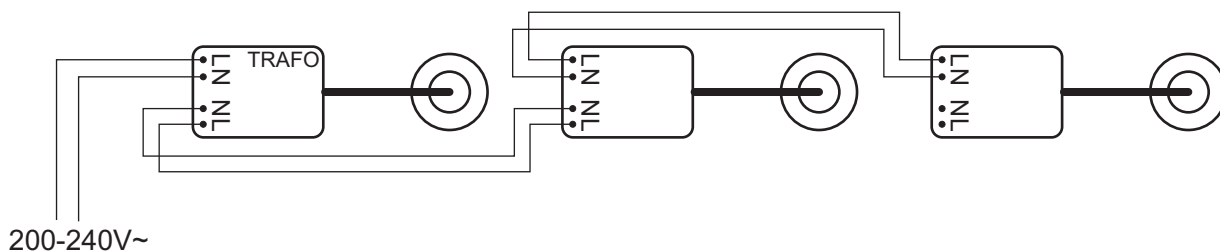
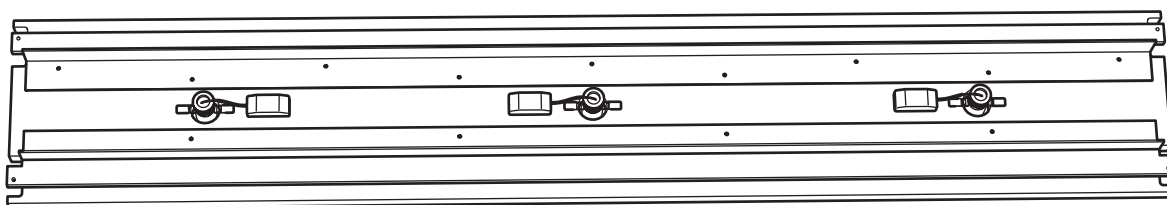

Kopplas in på Trafoplåt  
 Connected to Transformer plate

Trafoplåt  
Transformer plate

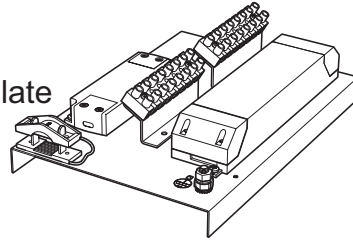

Trafoplåten placeras på valfri sida av takportalen, med fördel där den är lättast att komma åt för inkoppling.

**OBS! Trafoplåten skall inte placeras ännu.** Men tänk på att takportalen monteras så att kablarna till 200-240V~ från spotlighten hamnar på samma sida som Trafoplåten.

The transformer plate is placed on any side of the ceiling portal, preferably where it is easiest to access for connection.

**ATTENTION! The transformer plate must not be placed yet.** But keep in mind that the ceiling portal is mounted so that the cables for 200-240V~ from the spotlight end up on the same side as the transformer plate.

Placering av Trafoplåt för rum placerat i vänster hörn

Placement of transformer plate for room located in the left corner

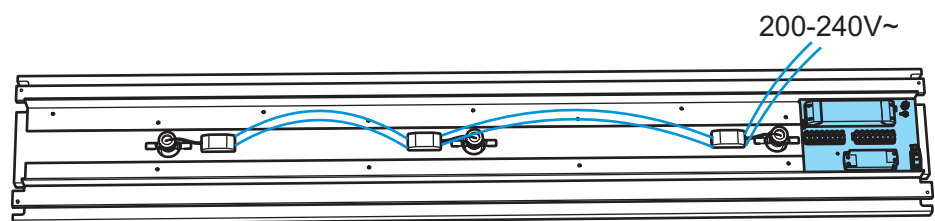
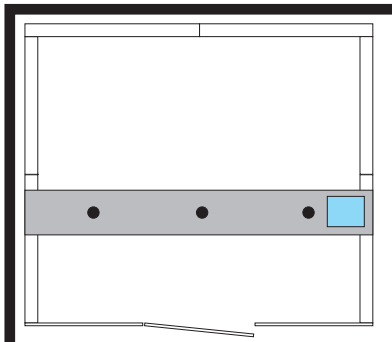

Placering av Trafoplåt för rum placerat i höger hörn

Placement of transformer plate for room located in the right corner

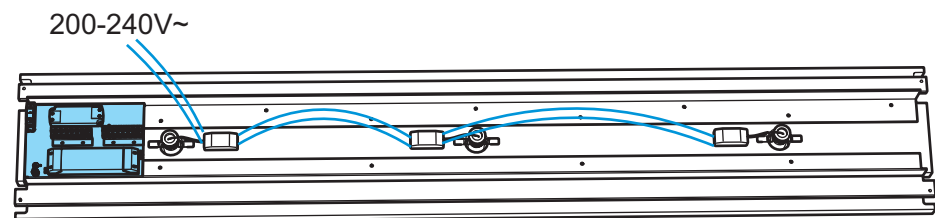
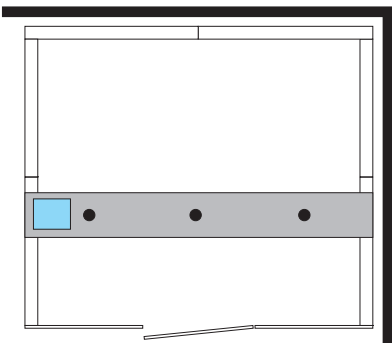

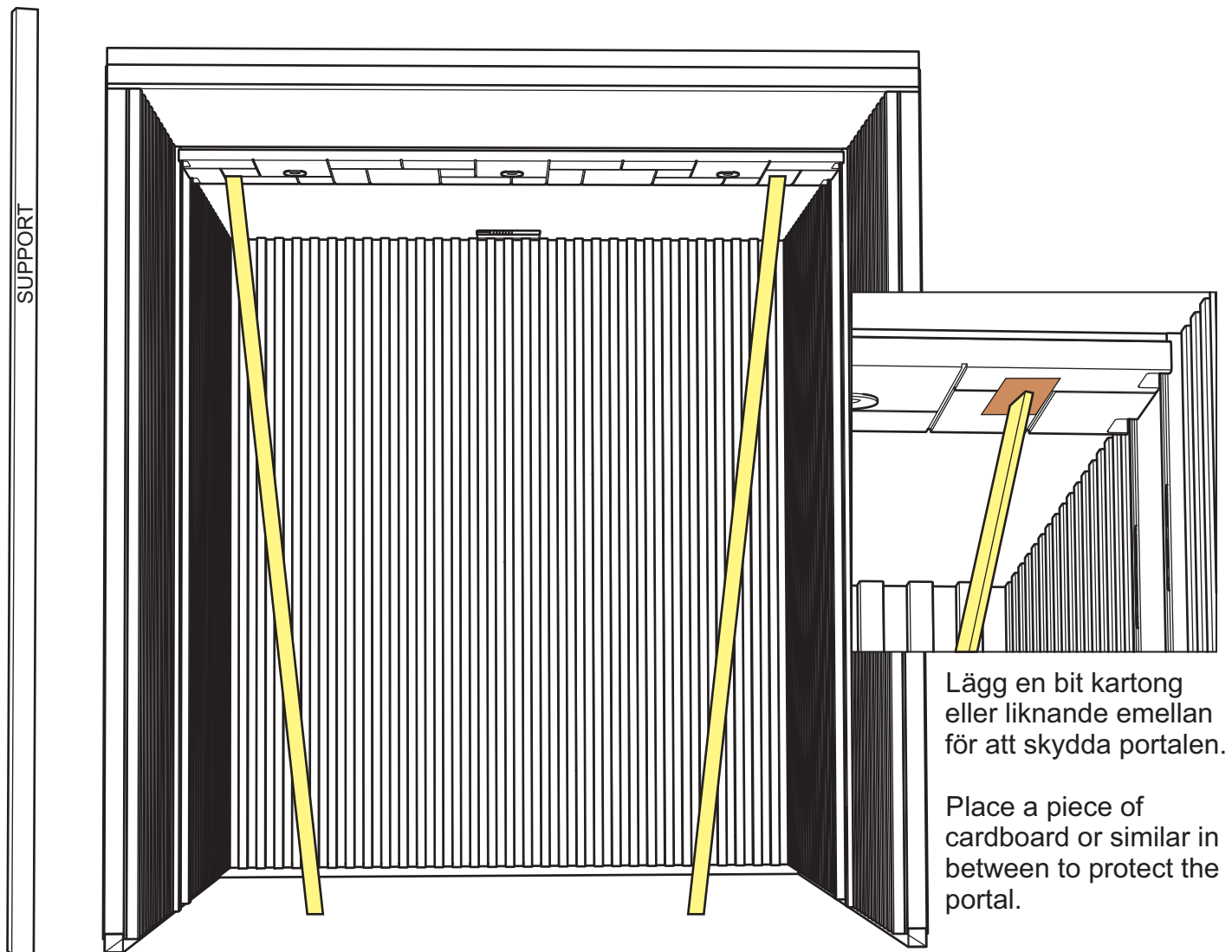

Rikta in takportalen så den är centrerad på båda sidor.  
Align the roof portal so that it is centered on both sides.

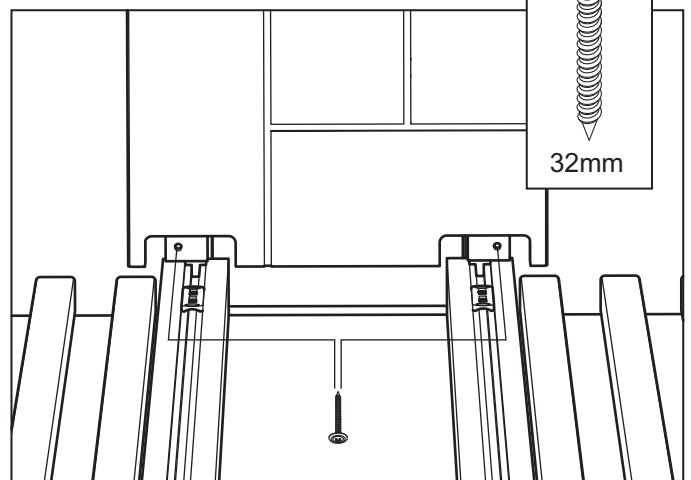
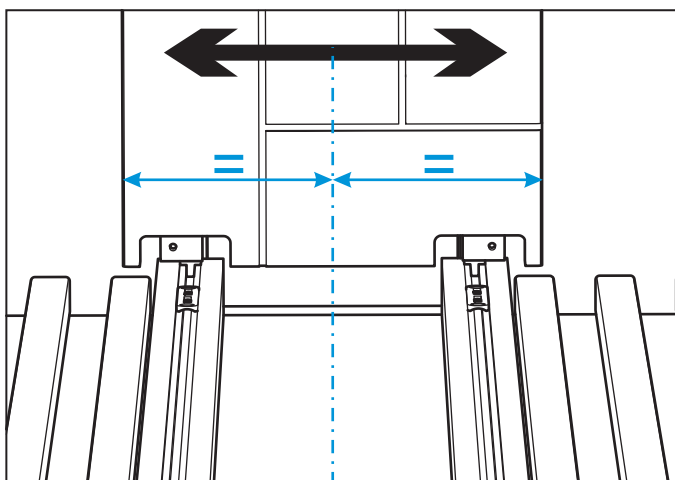

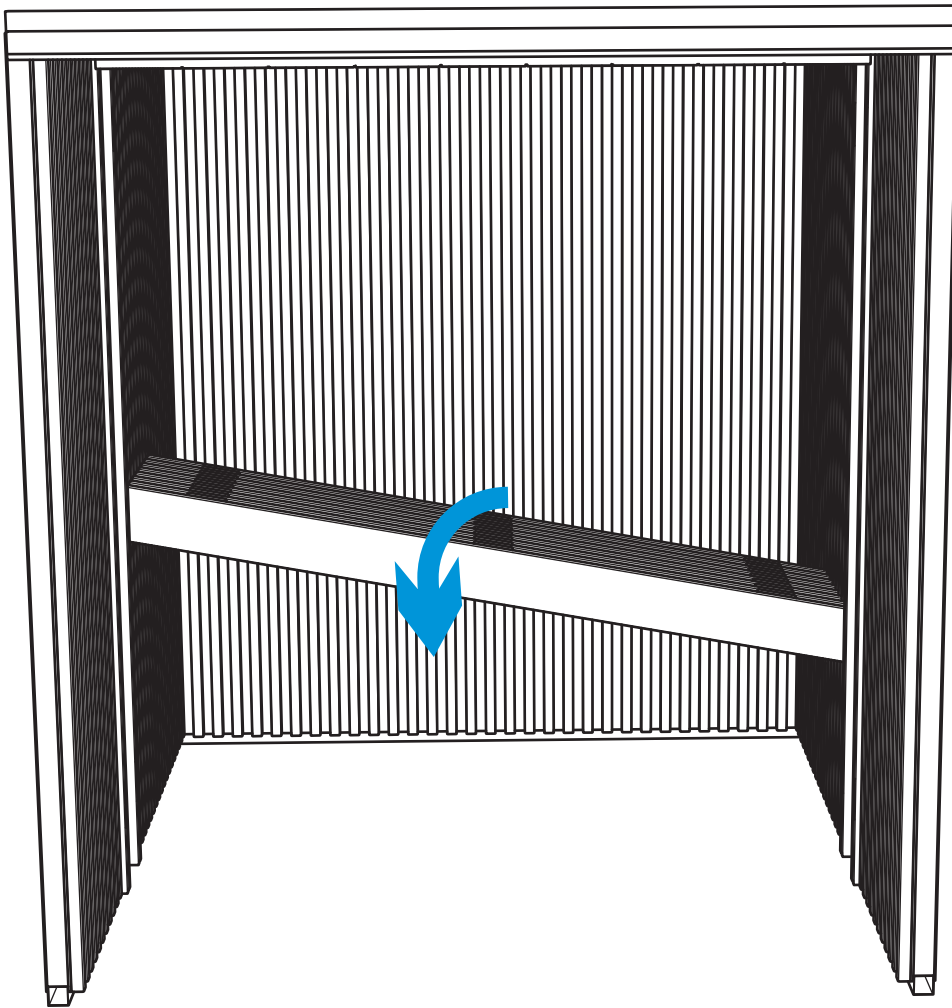

Lägg den nedre laven på plats. Se till att den hamnar i rätt spår på väggen, se bild nedan.

Put the lower bench in place. Make sure it ends up in the right groove on the wall, see picture below.

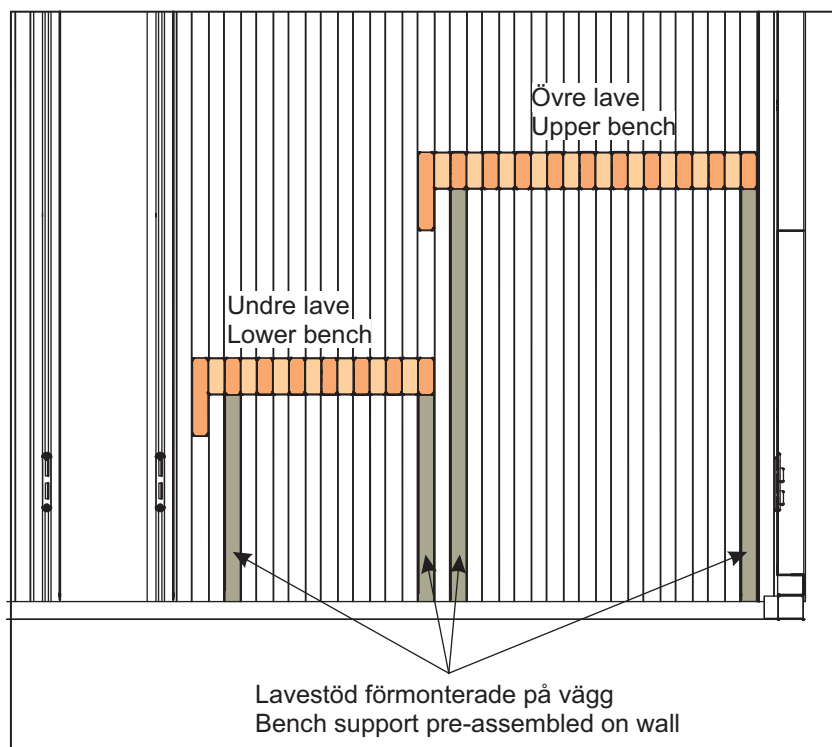

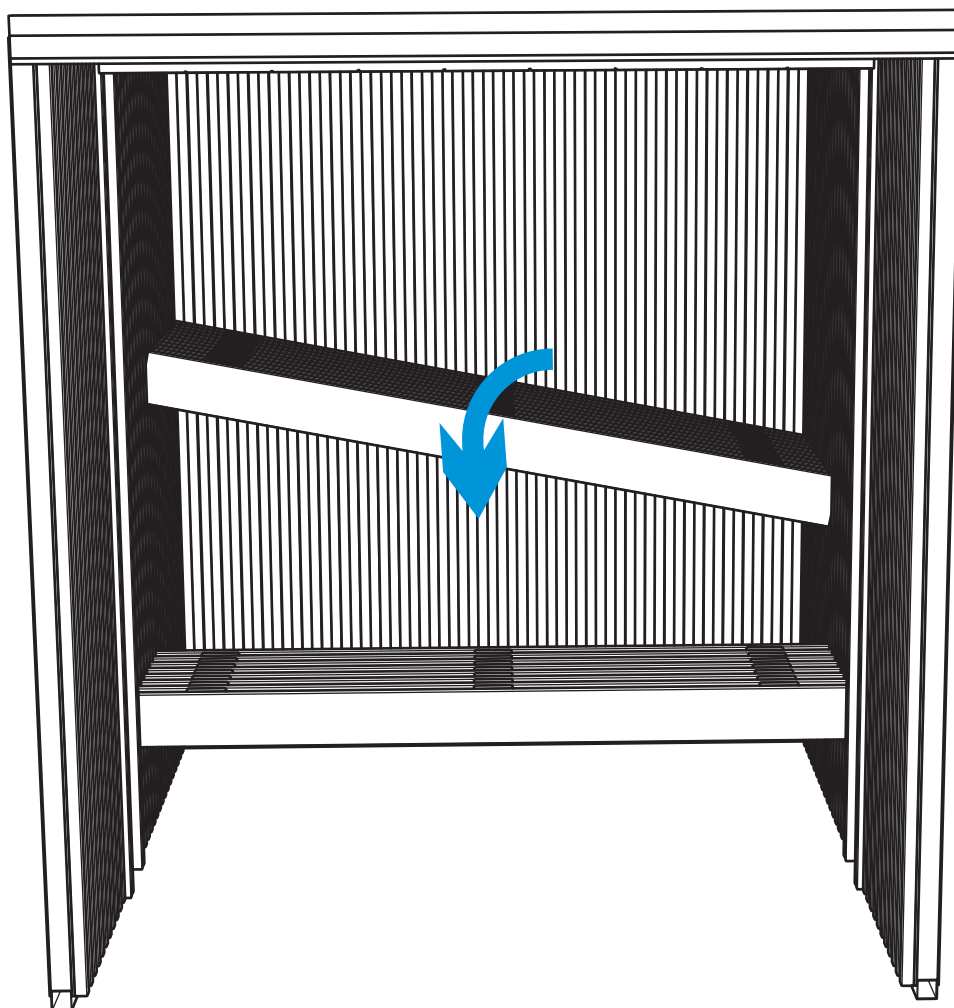

Lägg den övre laven på plats. Se till att den hamnar i rätt spår på väggen, se bild föregående sida.

Put the upper bench in place. Make sure it ends up in the right groove on the wall, see picture previous page.



# 18

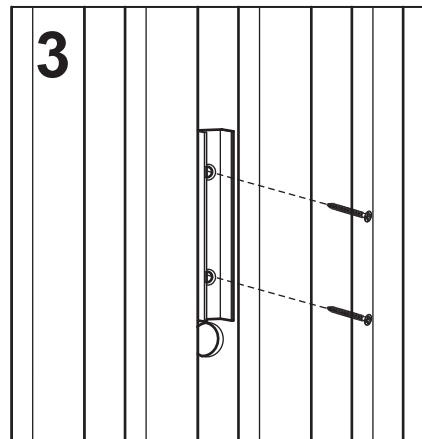
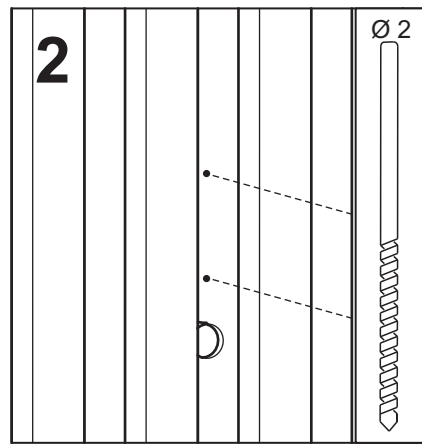
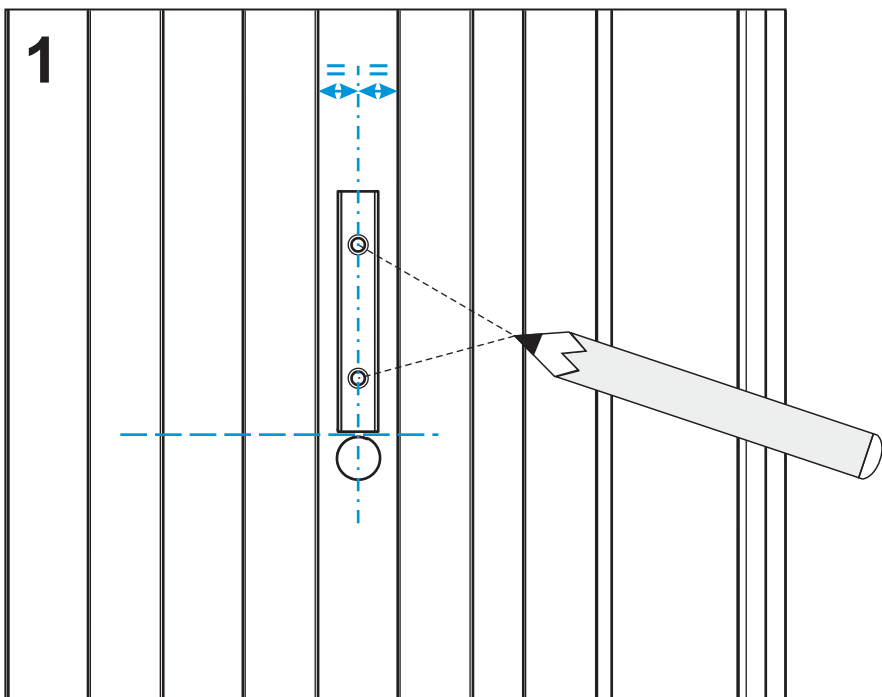
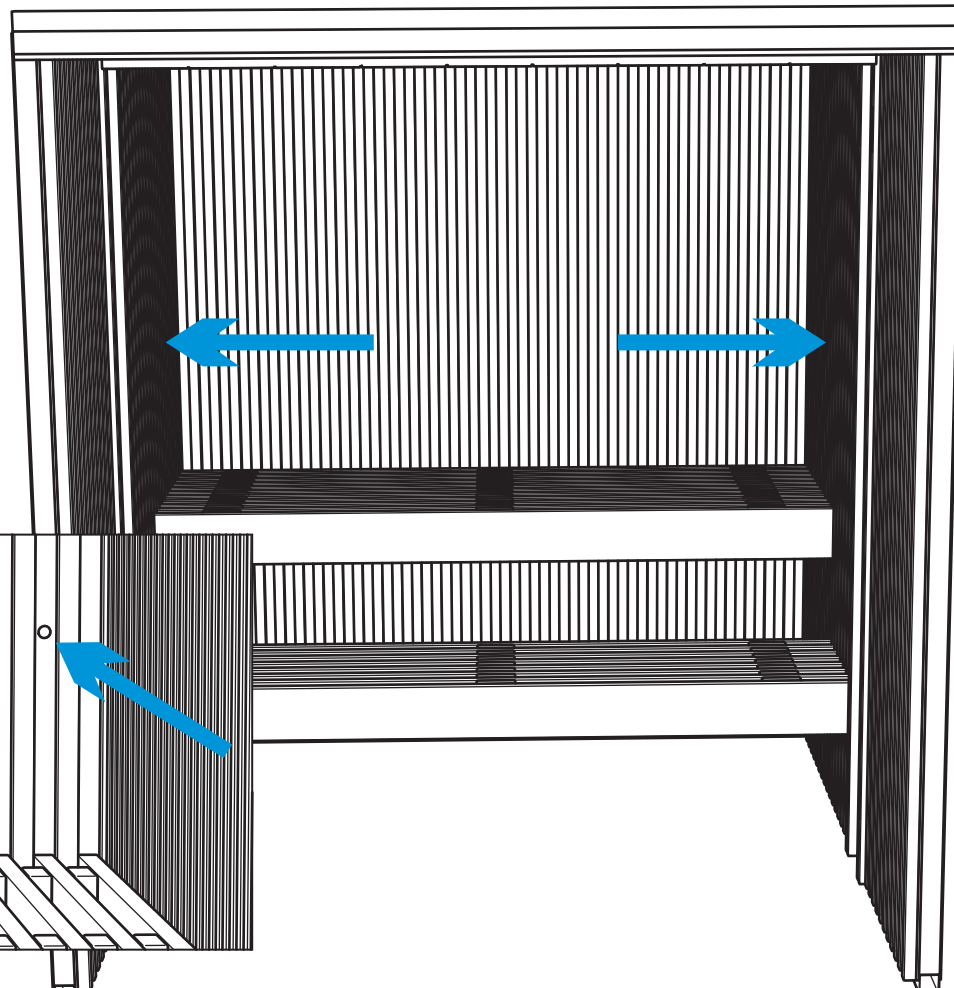
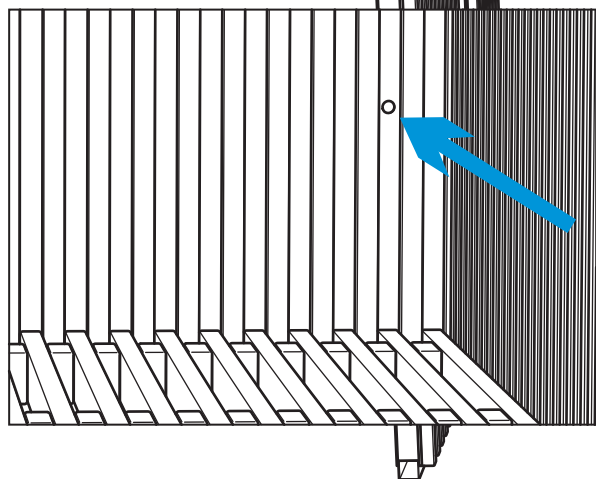
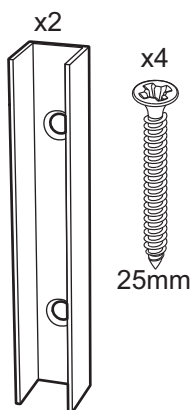

Håll U-profilen mot övre kanten på hålet och se till att den är centrerad mellan ribborna på väggen. Rita märke enligt bild. Borra hål och skruva upp profilerna på båda sidor av rummet.

Hold the U-profile against the top edge of the hole and make sure it is centered between the ribs on the wall. Draw mark according to picture. Drill holes and screw up the profiles on both sides of the room.

19

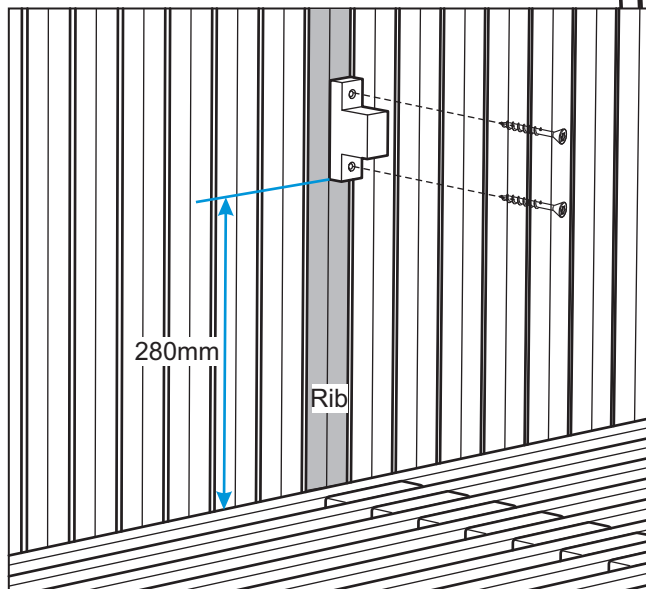
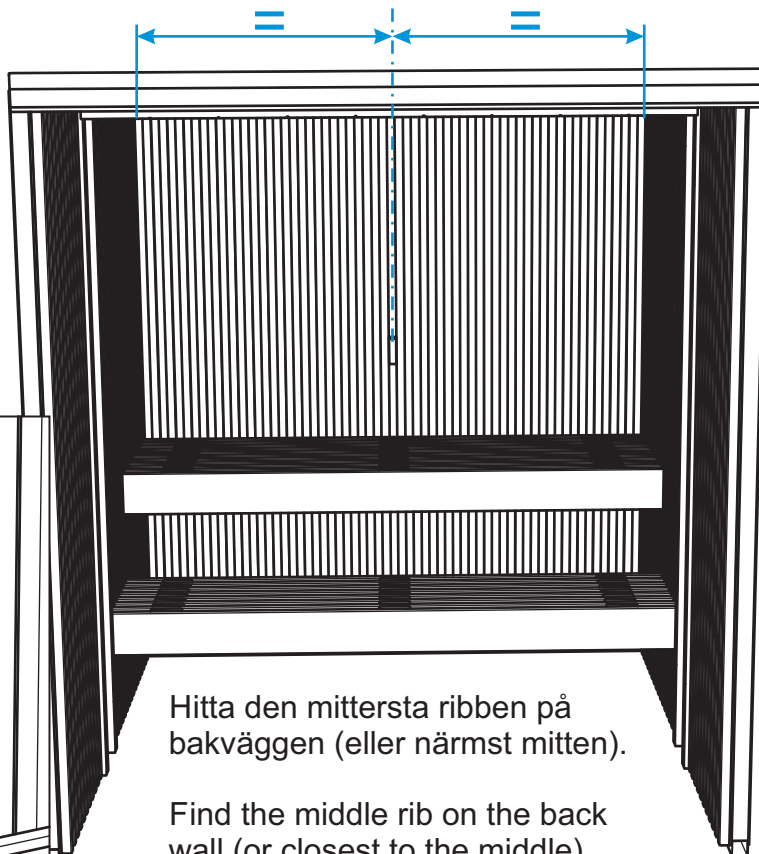
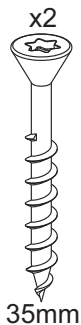
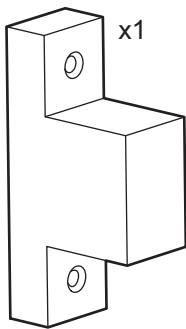

Hitta den mittersta ribben på bakväggen (eller närmst mitten).

Find the middle rib on the back wall (or closest to the middle).

Ryggstödet kan monteras med kabeldragning på höger eller vänster sida.

The backrest can be mounted with cable routing on the right or left side.

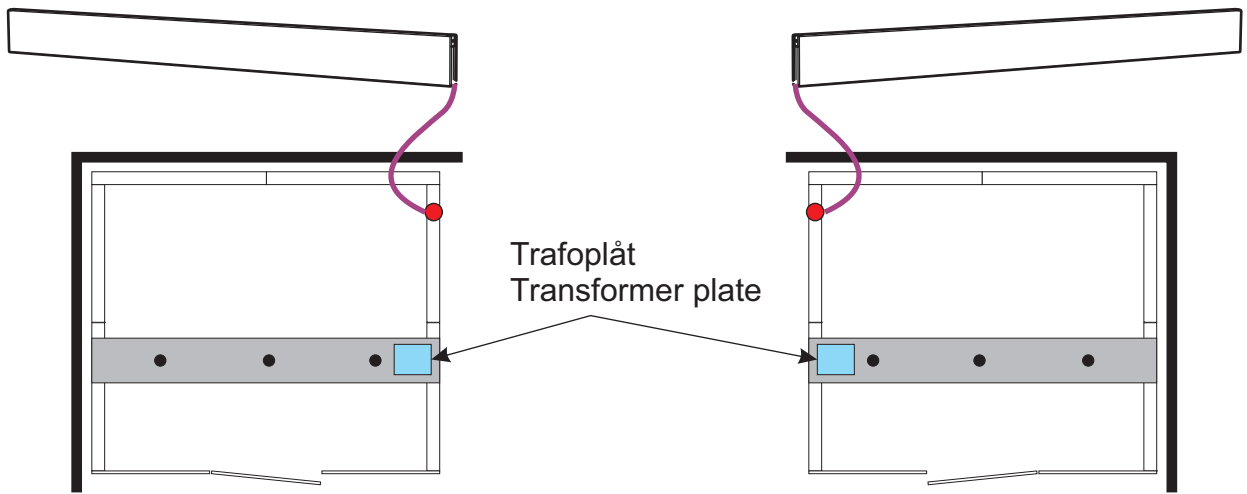
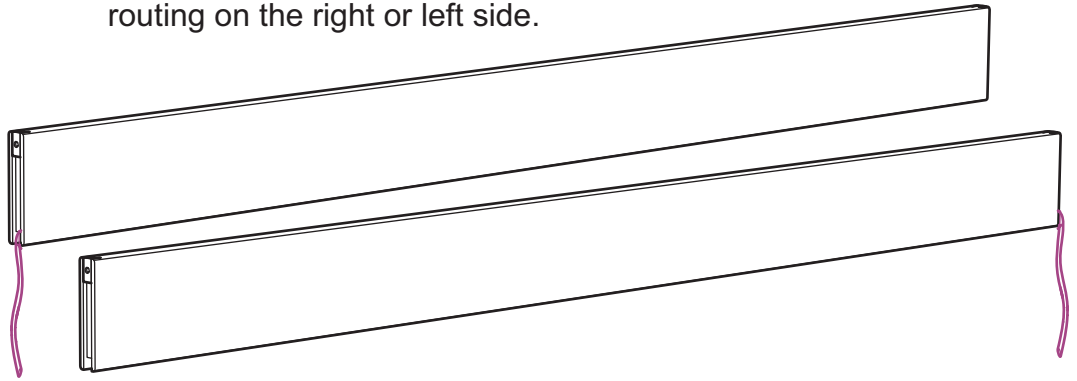

Trafoplåt  
Transformer plate

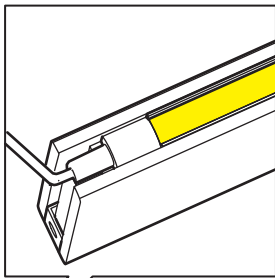
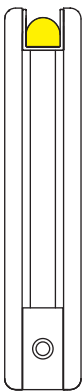

Tryck på ledlisten med träklossen för att få ner ledlisten i U-profilen.  
Press the led strip with the wooden block to bring the led strip down into the U-profile.

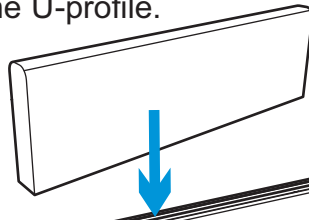

Börja med änden där kabeln sitter.  
Start with the end where the cable is.

Skär av ledlisten i linje med U-profilen.  
Cut off the led strip in line with the U-profile.

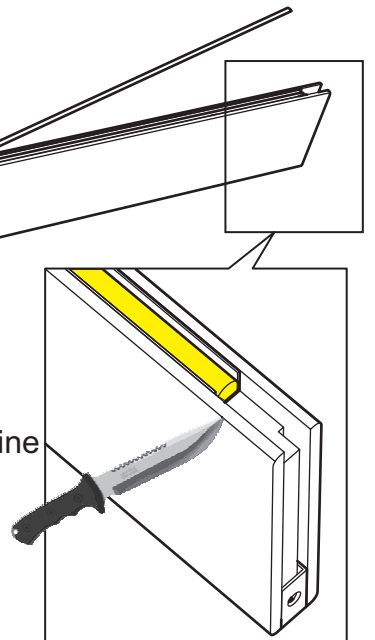

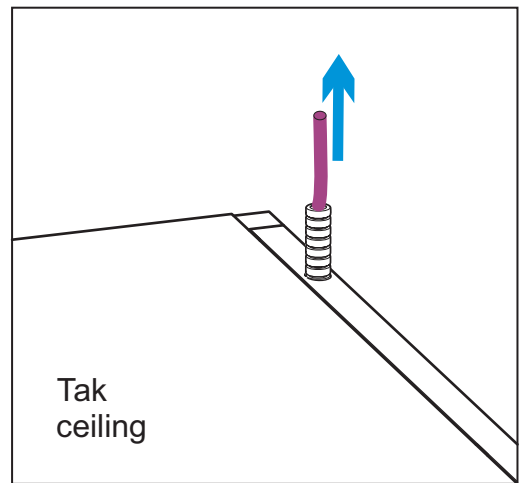
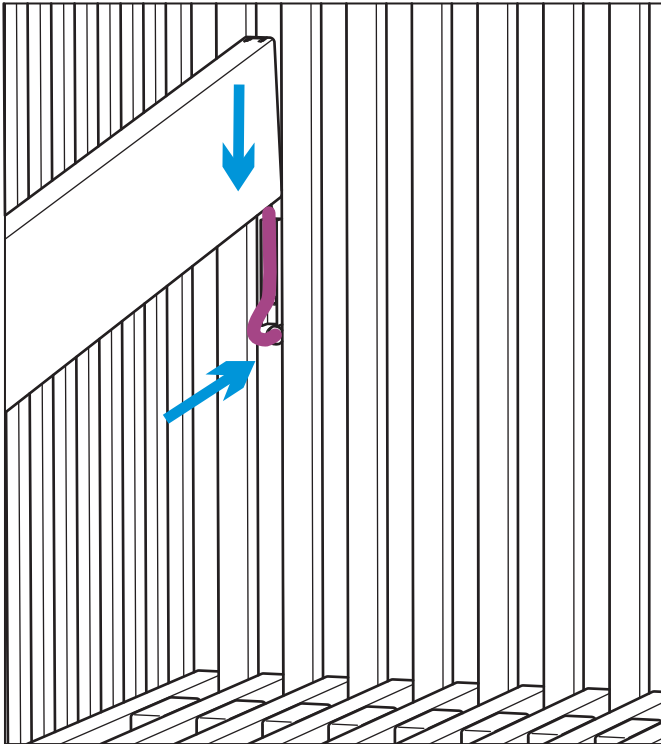
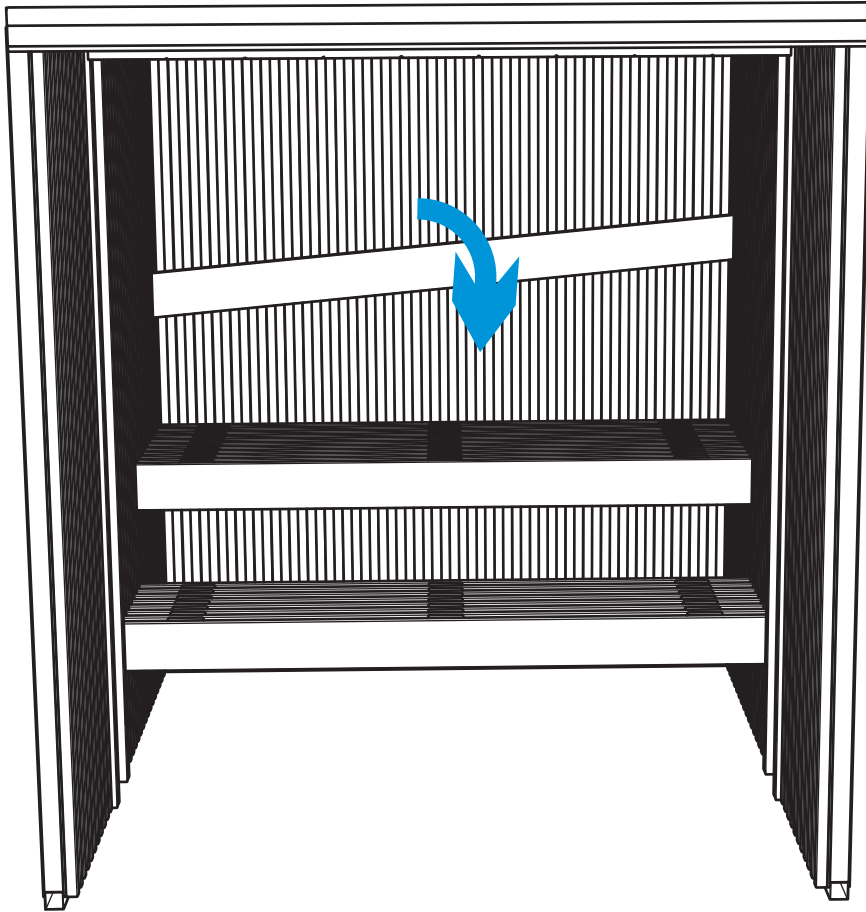

# 22

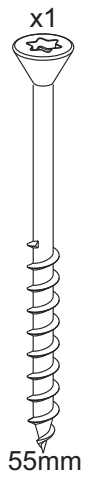
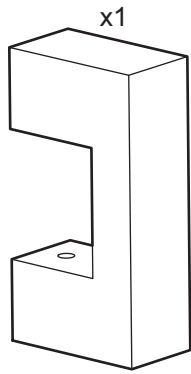

Dra ryggstödet utåt i mitten och skruva dit distansklossen.

Pull the backrest outwards in the middle and screw the spacer block there.

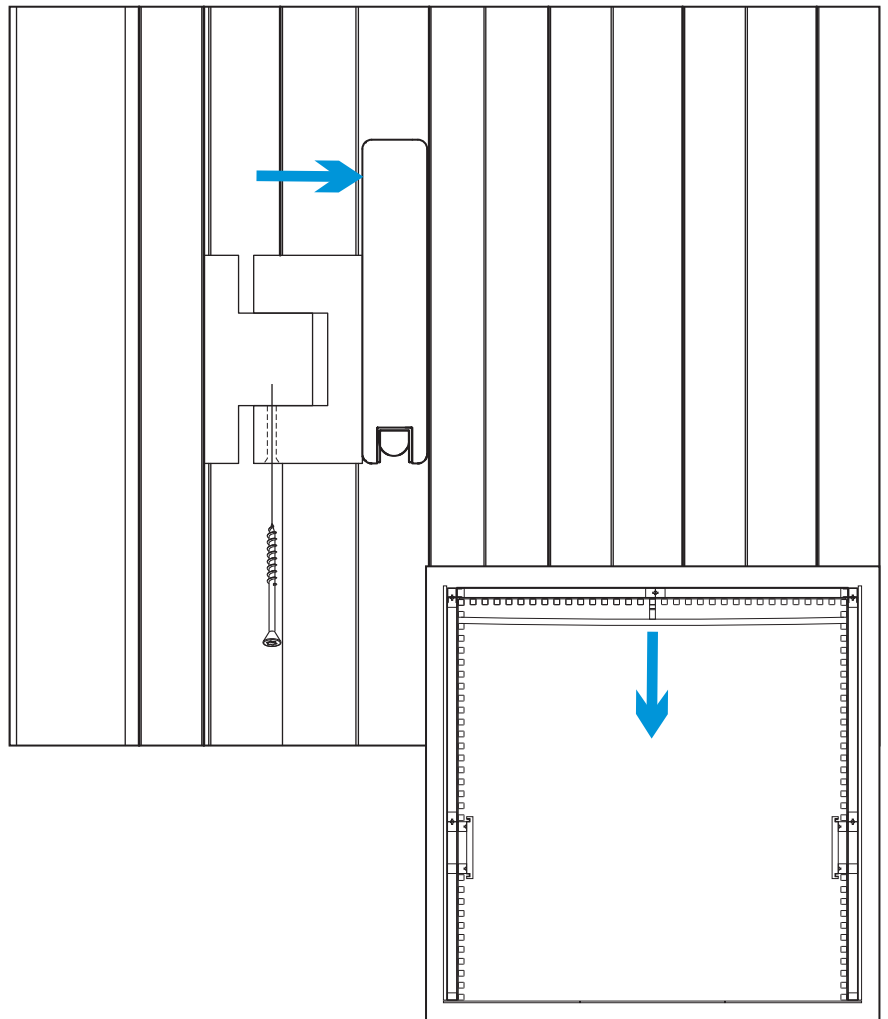

## 23

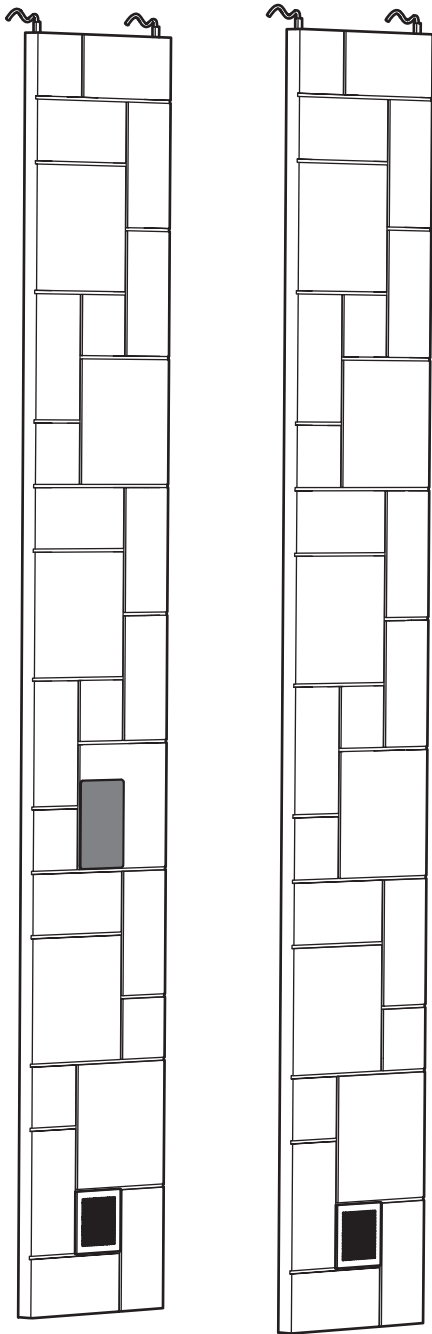
**Väggportaler med ljuslister, högtalare och manöverpanel**  
**Wall portals with light strips, speakers and control panel**

Väggportalerna är likadana förutom att det sitter en manöverpanel i den ena. Välj vilken sida av rummet manöverpanelen ska placeras innan montering. OBS! Tänk på att om en extra sidolave ska monteras, att den inte hamnar framför panelen.

The wall portals are the same except that there is a control panel in one. Choose which side of the room the control panel should be placed on before installation. ATTENTION! Keep in mind that if an extra side bench is to be fitted, that it does not end up in front of the panel.

24

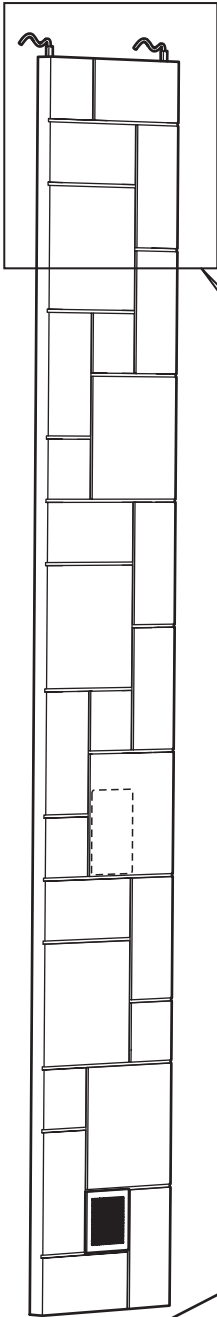

Sensorn till aggregatet placeras på den väggportal som är närmast aggregatet.  
För inkoppling av sensor, se manual som medföljer aggregatet.

The sensor for the heater is placed on the wall portal closest to the heater.  
For connecting the sensor, see the manual that comes with the heater.

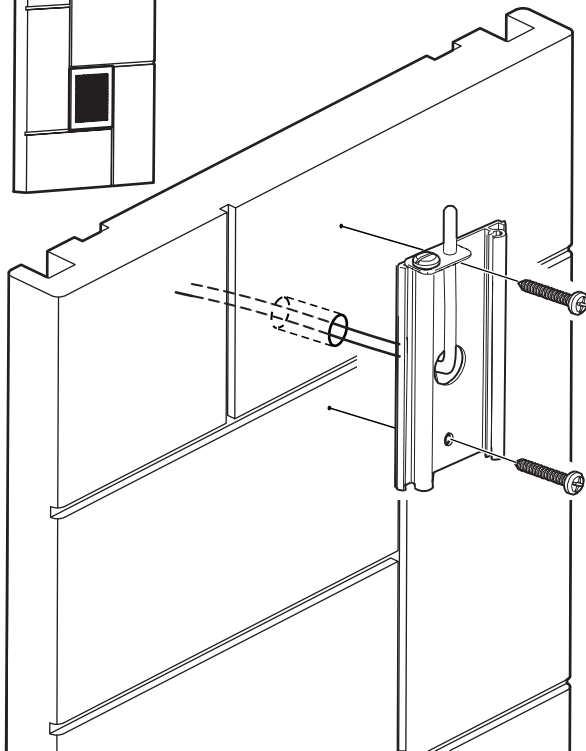
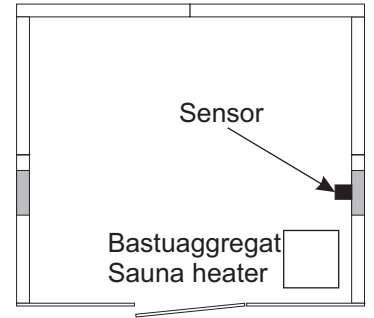
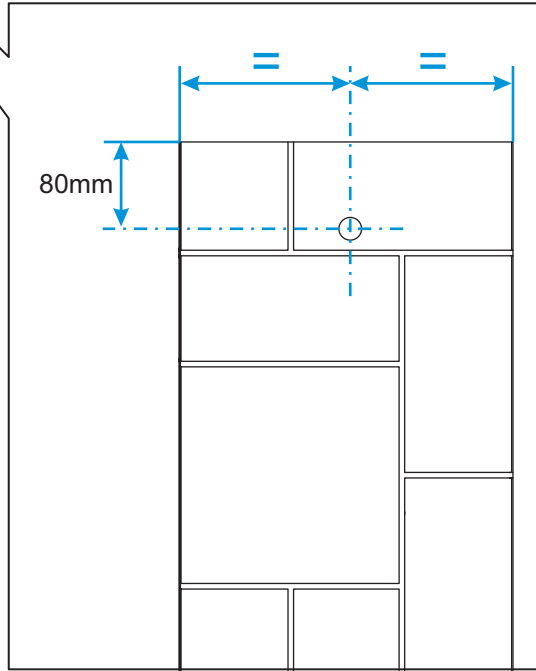

Ledningsdragning genom portal för tempsensor.  
Wiring through the portal for Temp sensor.

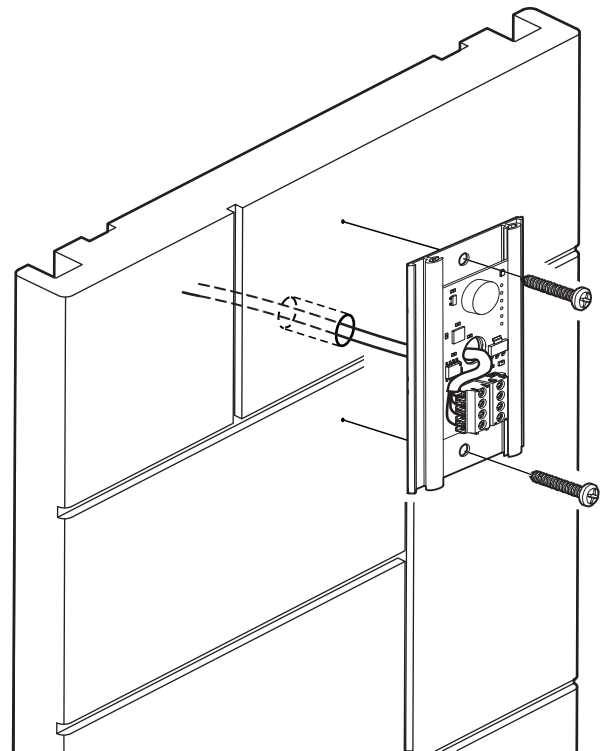

Ledningsdragning genom portal för fukt/tempsensor.  
Wiring through the portal for Temp/humidity sensor.

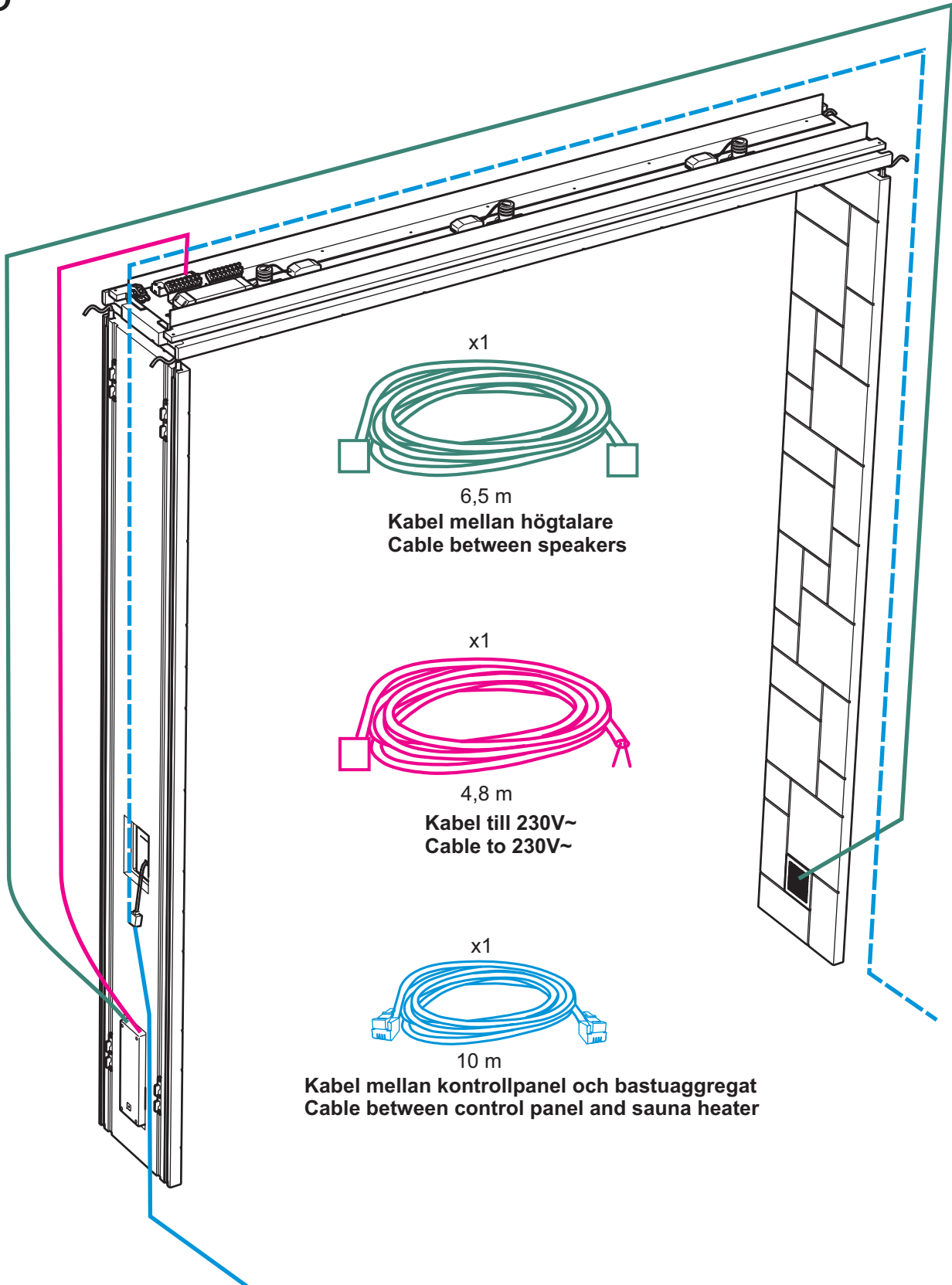

x1  
 6,5 m  
**Kabel mellan högtalare**  
**Cable between speakers**

x1  
 4,8 m  
**Kabel till 230V~**  
**Cable to 230V~**

x1  
 10 m  
**Kabel mellan kontrollpanel och bastuaggregat**  
**Cable between control panel and sauna heater**

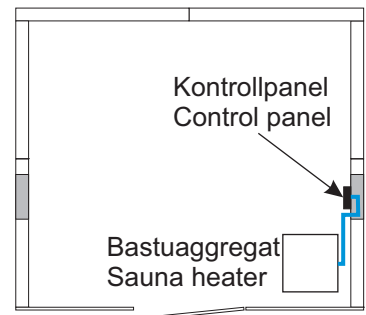
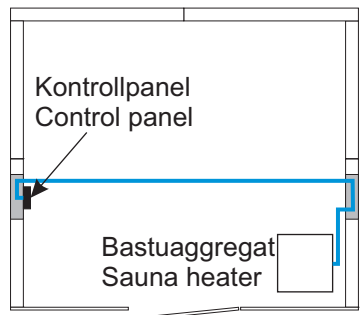



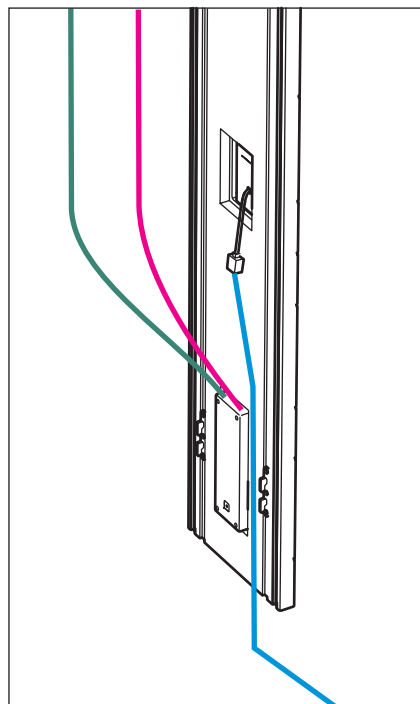
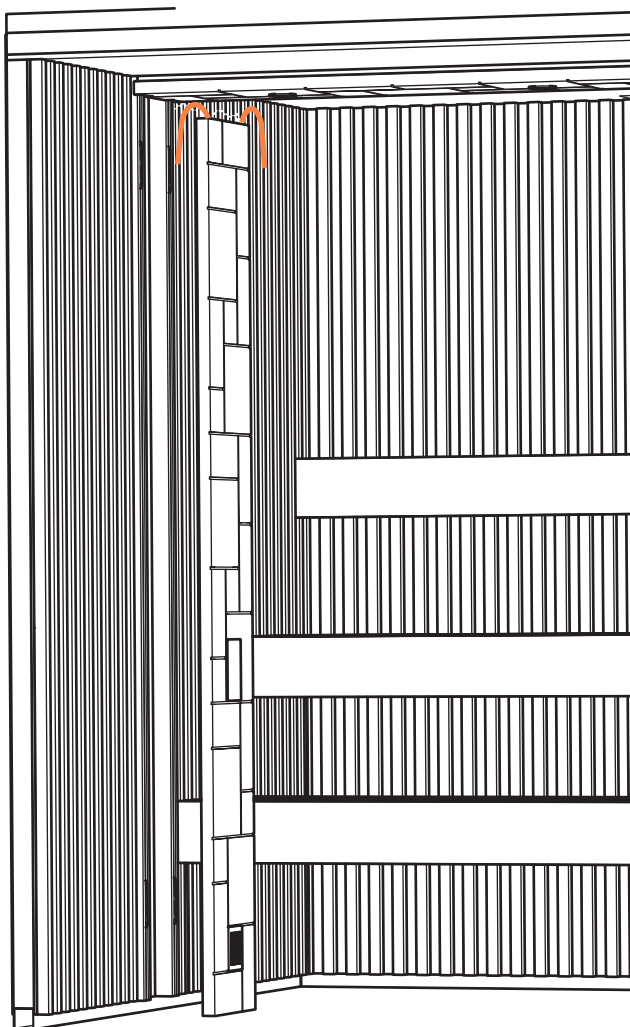

Koppla de 3 kablarna på portalen med manöverpanelen.

Connect the 3 cables on the portal with the control panel.

Dra kablarna till ledlisterna upp på taket enligt bild. Kablarna till högtalaren och eventuellt till manöverpanelen dras upp i mitten.

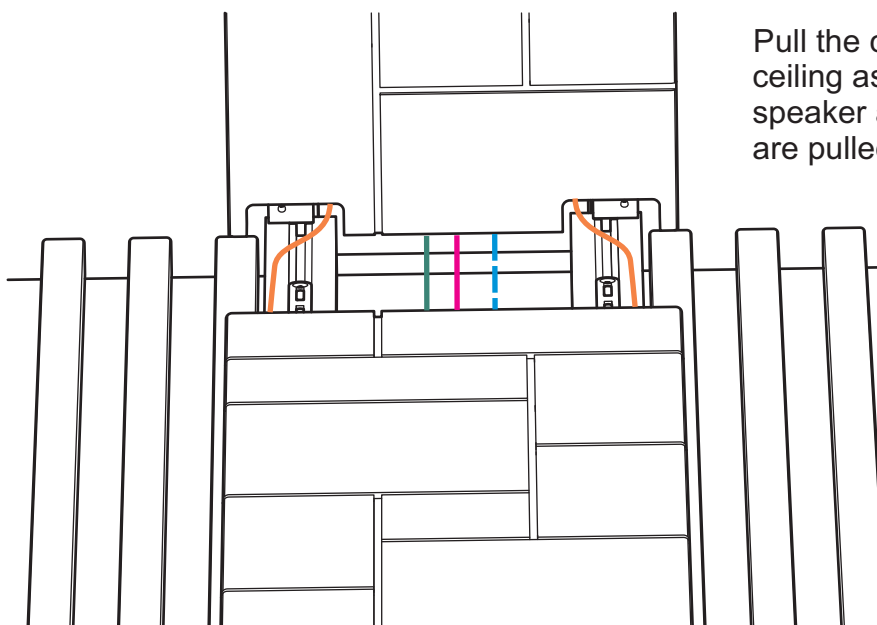

Pull the cables to the led lists up on the ceiling as shown. The cables to the speaker and possibly to the control panel are pulled up in the middle.

27

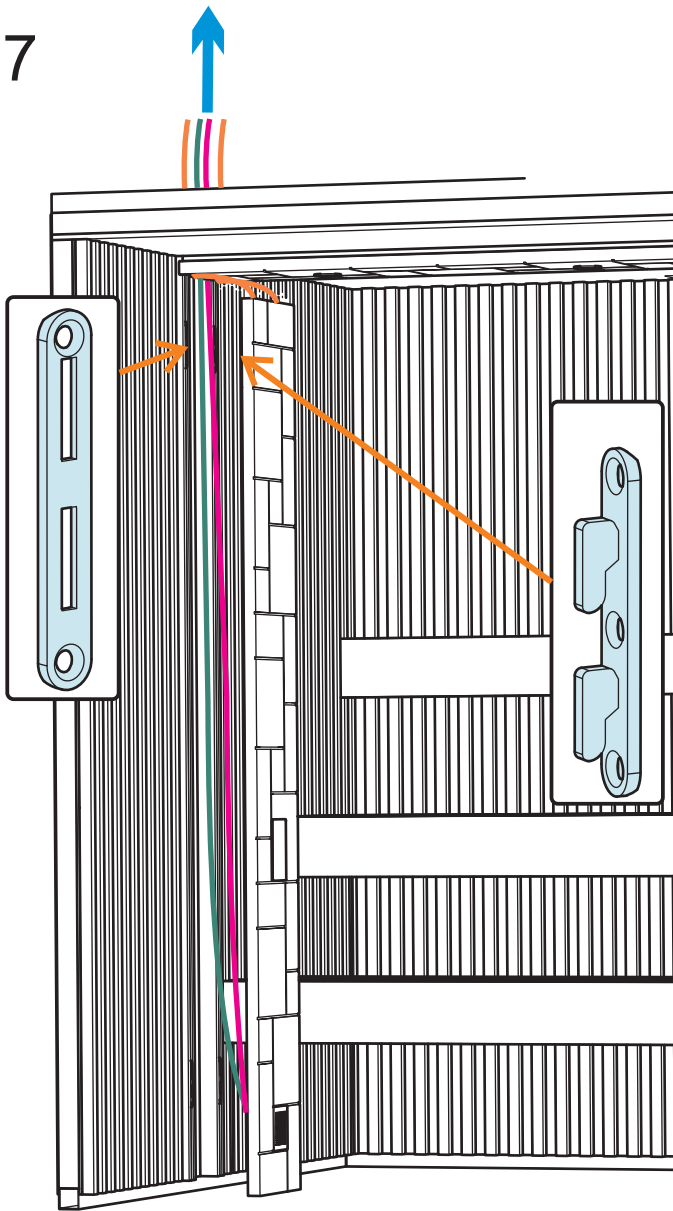

Sträck på kablarna och haka fast portalen i väggen. Kabel mellan högtalare dras över taket och ner till den andra portalen.

Stretch the cables and hook the portal to the wall. Cable between speakers is pulled over the roof and down to the other portal.

Koppla kabeln mellan högtalarna och haka fast den andra portalen i väggen.

Connect the cable between the speakers and hook the other portal to the wall.

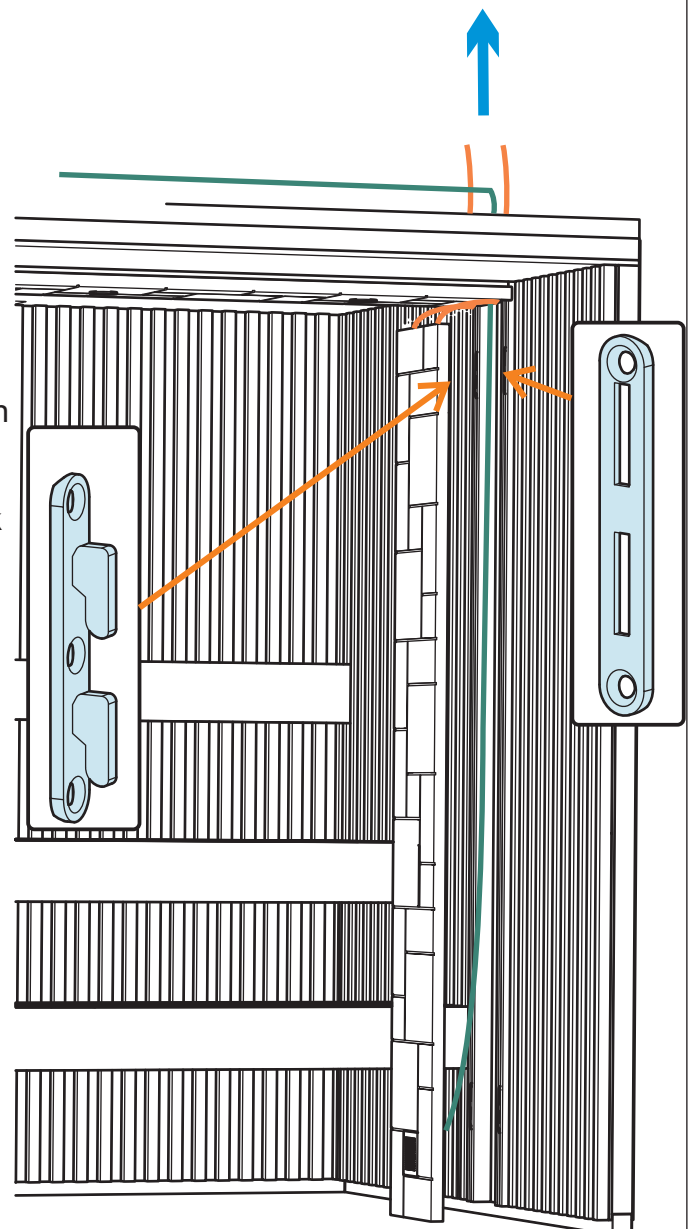
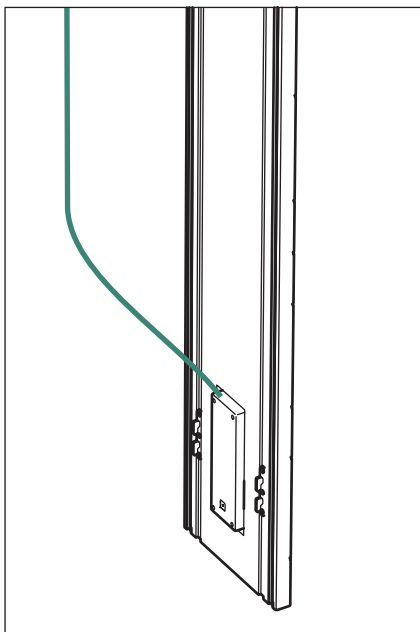

# 28

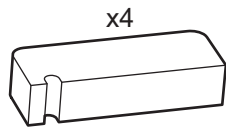

Sätt dit packningarna på båda sidor av takportalen, dra kablarna till ledlisterna i hålet.

Place the gaskets on both sides of the ceiling portal, run the cables to the led lists in the hole.

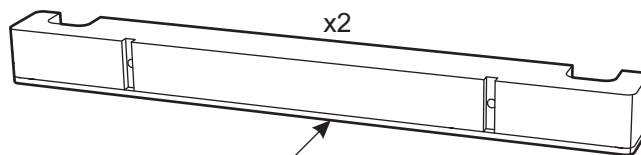
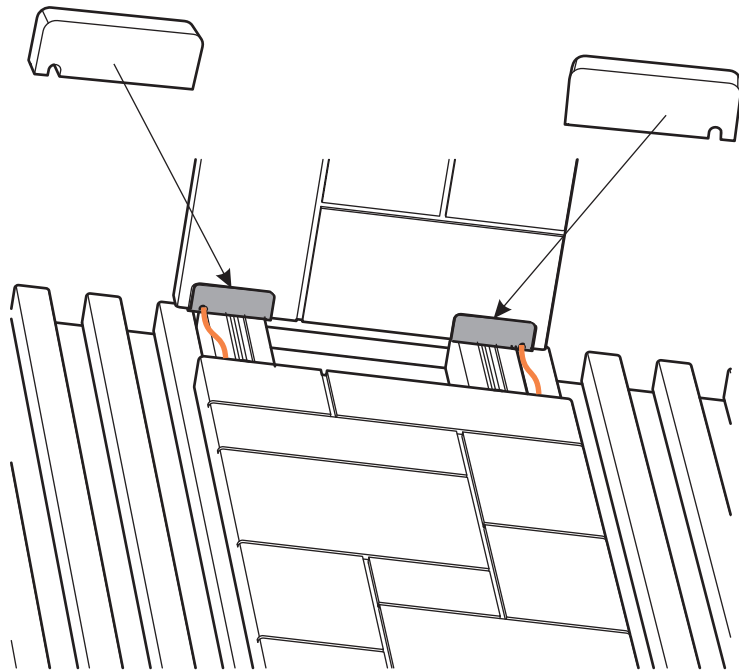

Packning neråt  
Gasket downwards

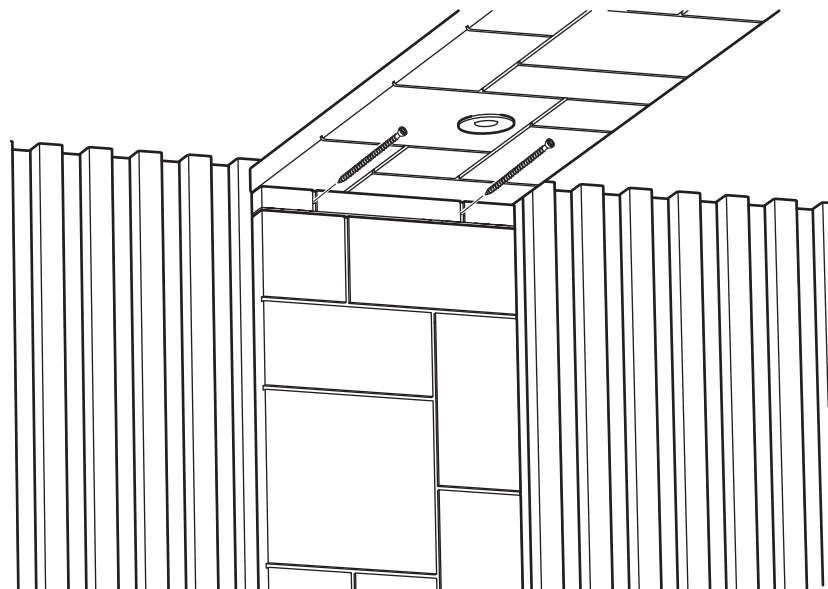

OBS! Det är viktigt att väggar och tak är vinkelräta, 90°. Det är också viktigt att måtten är samma mellan sidoväggarna både uppe och nere.

ATTENTION! It is important that walls and ceiling are perpendicular, 90°. It is also important that the dimensions are the same between the side walls both at the top and bottom.

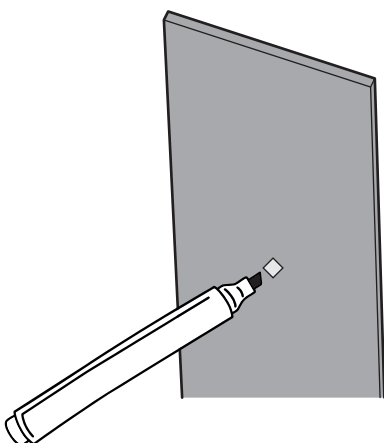
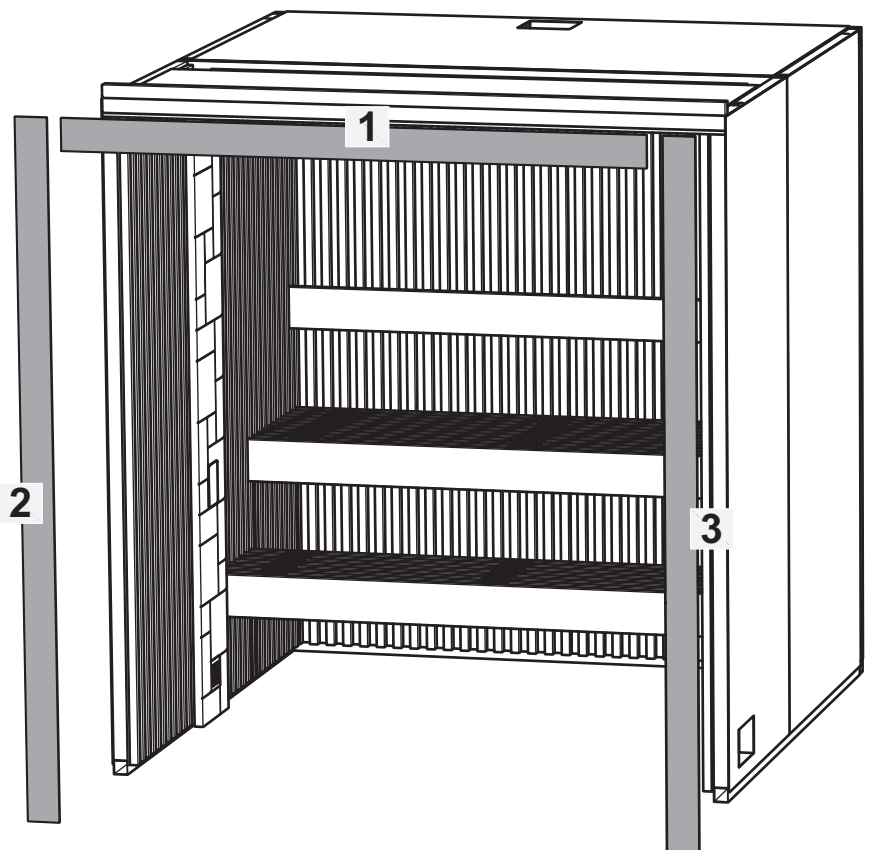
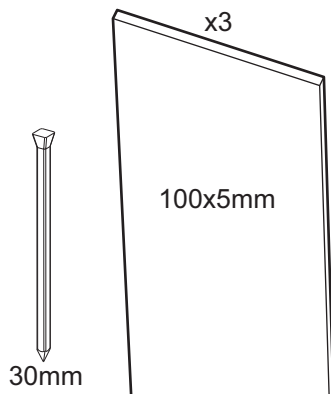
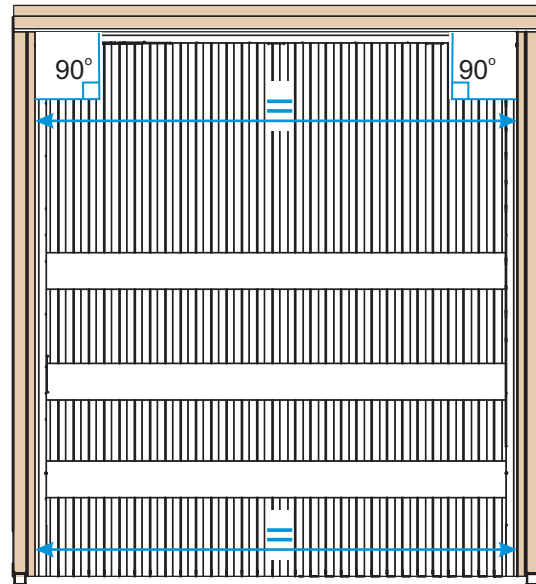

Göm spikhuvudet med en svart tuschpenna  
Hide the nail head with a black marker pen

Tips! Använd stiftpistol om det finns.  
Tip! Use a nail gun if available.

30

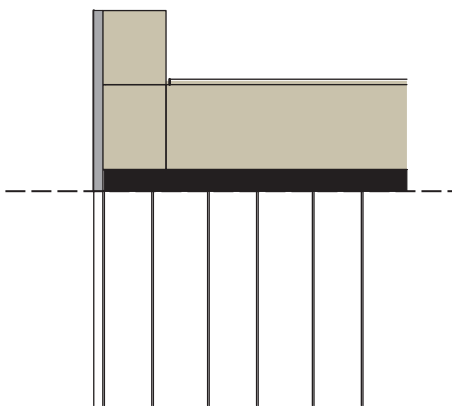
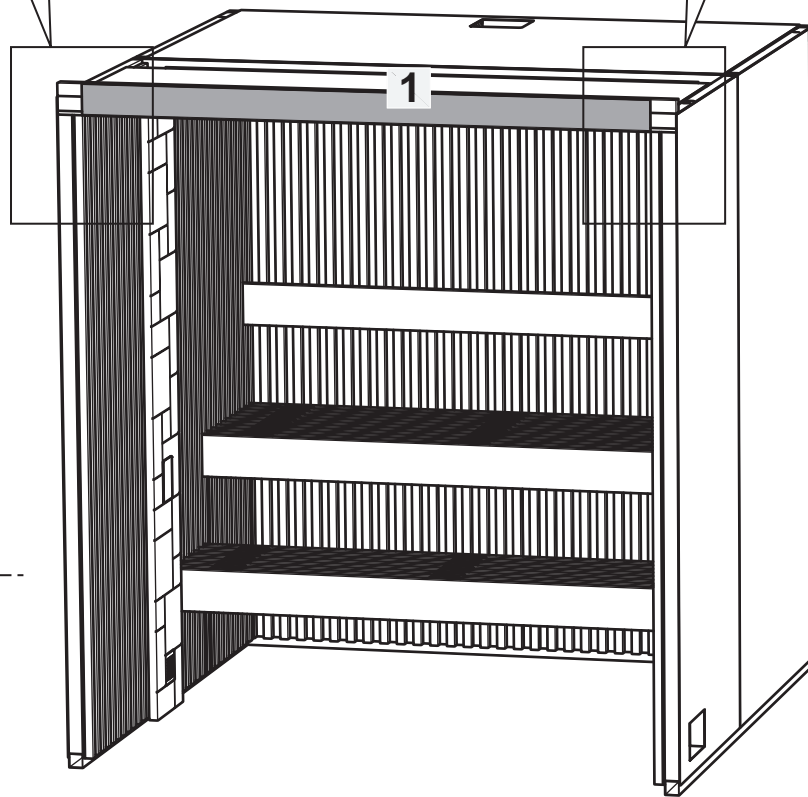
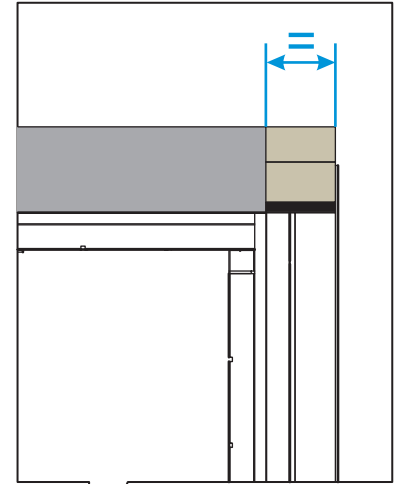
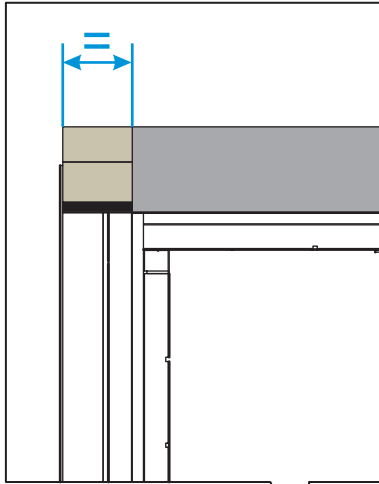
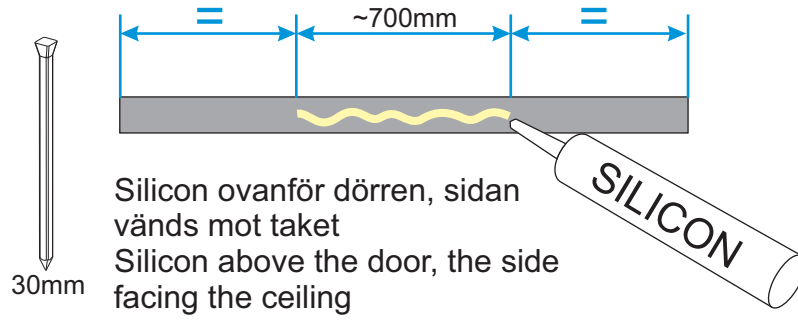

Kant i kant med insida tak  
Edge to edge with ceiling inside

31

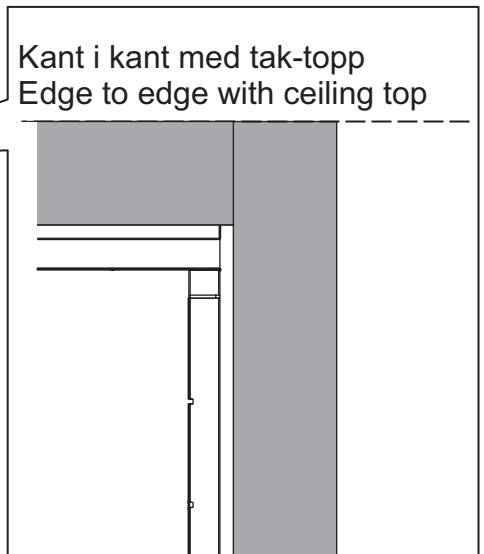
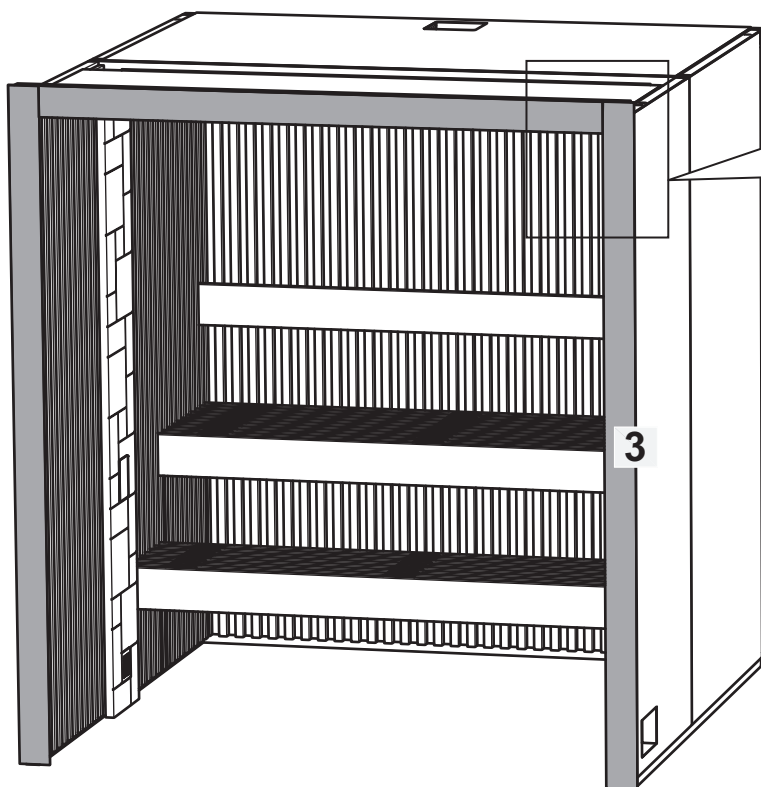
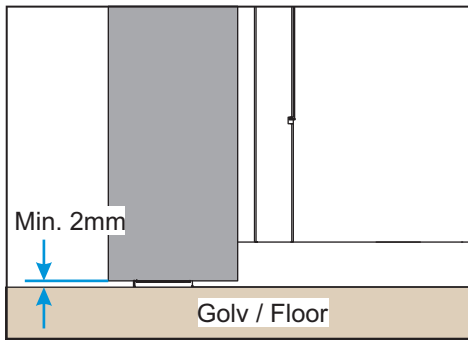
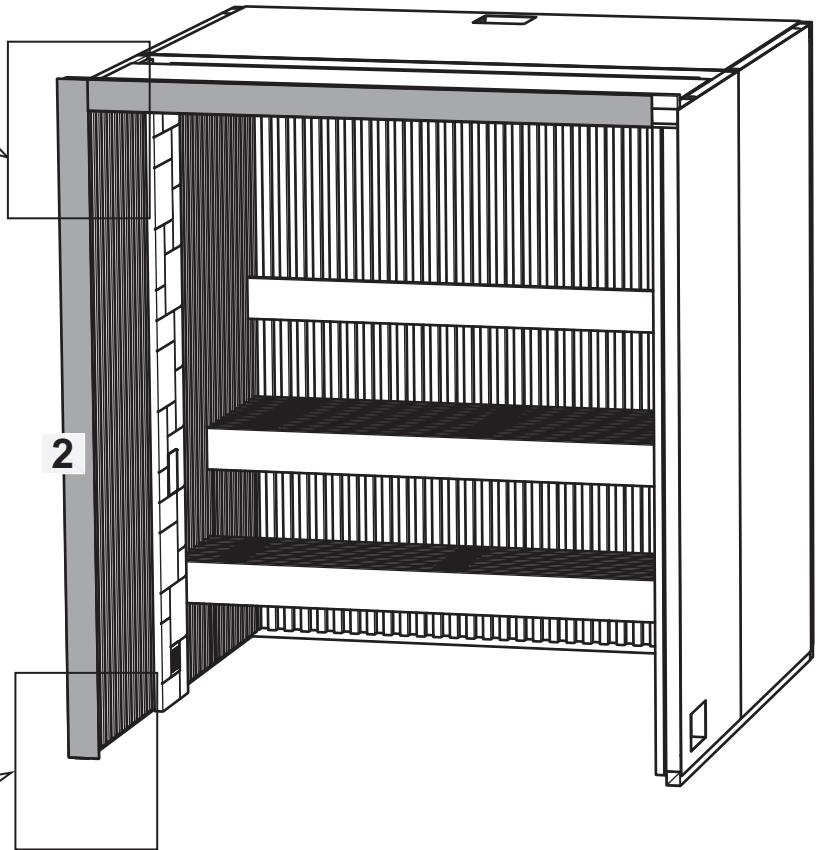
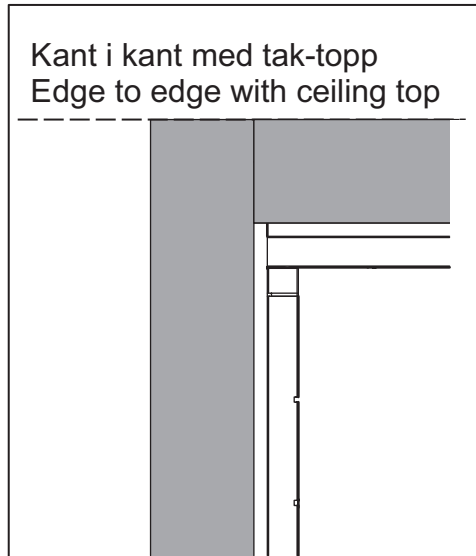

# 32

Dörren kan monteras höger- eller vänsterhängd. OBS! Gäller ej rum Glass Corner!  
The door can be mounted right- or left-hung. ATTENTION! Does not apply to Glass Corner rooms!

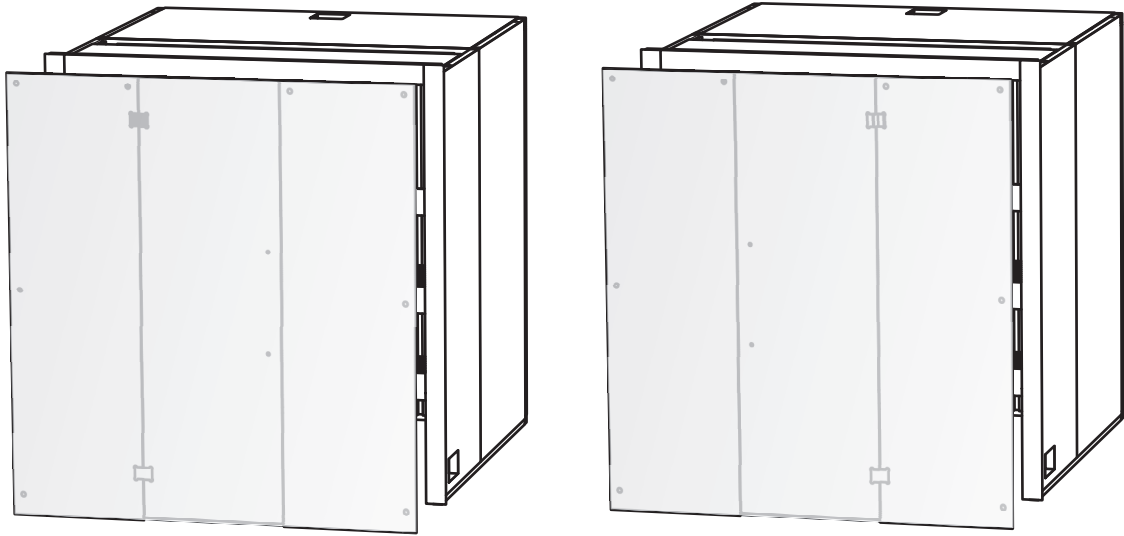

Varning! Glas - behandlas varsamt!  
Warning! Glass - handle with care!

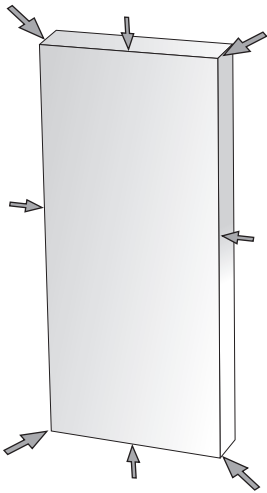

Kanterna på glaset bör skyddas från slag och stötar.  
The edges of the glass should be protected from knocks and impacts.

Placering av glas  
Glass placement

Alt. 1

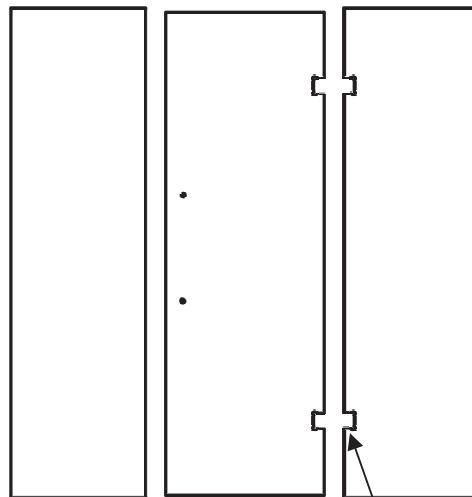

Gångjärn-höger  
Hinges-right

Alt. 2

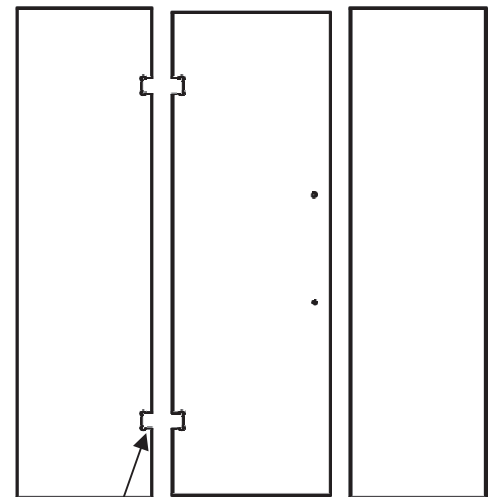

Gångjärn-vänster  
Hinges-left

Putsa insidan på glaset där glas möter vägg innan de monteras upp.  
Kontrollera att ingen smuts hamnar mellan glas och vägg.  
Polish the inside of the glass where the glass meets the wall before mounting.  
Check that no dirt gets between the glass and the wall.

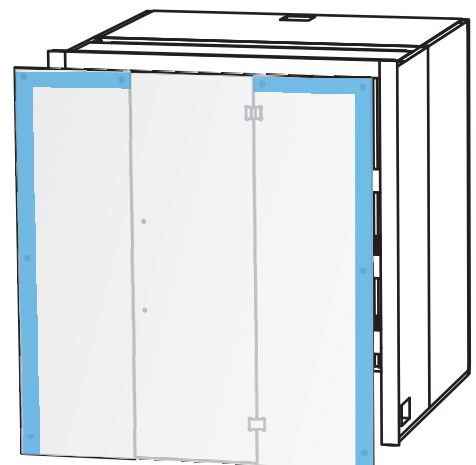

33

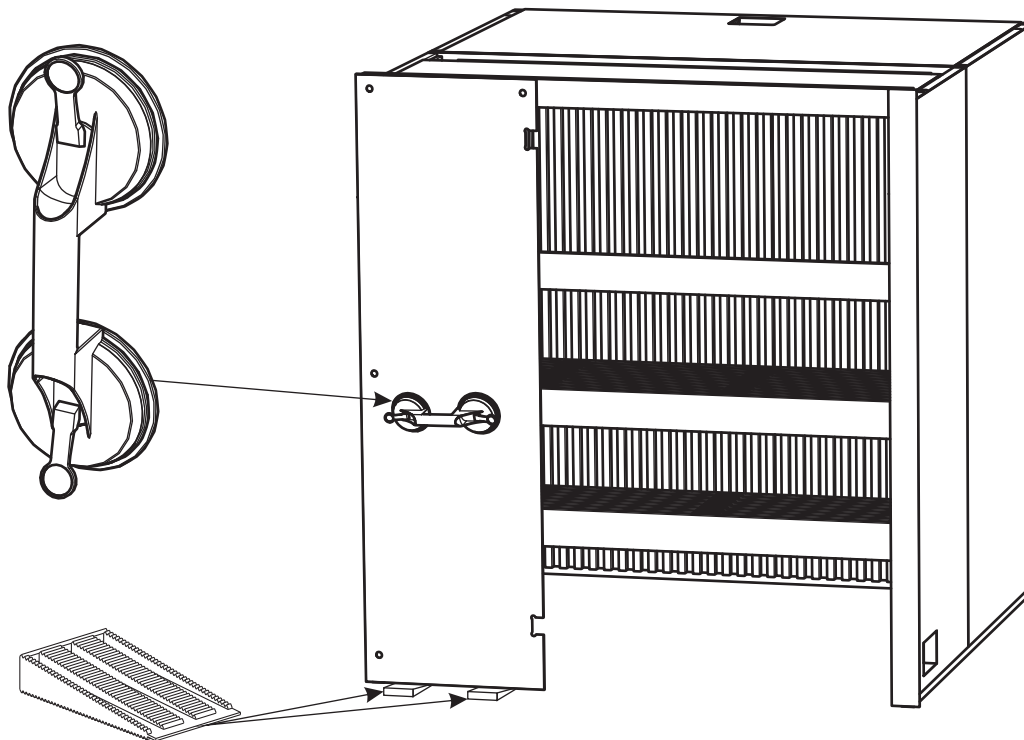

Glaset skall monteras kant i kant med den svarta ramen men om måttet till golv är mindre än 3mm måste glaset höjas.

The glass should be mounted edge to edge with the black frame, but if the dimension to the floor is less than 3mm, the glass must be raised.

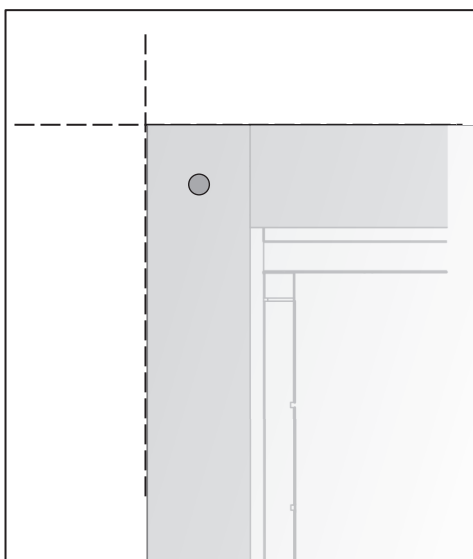

Kant i kant med svart ram  
Edge to edge with black frame

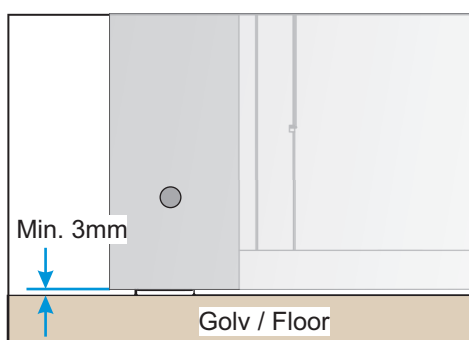
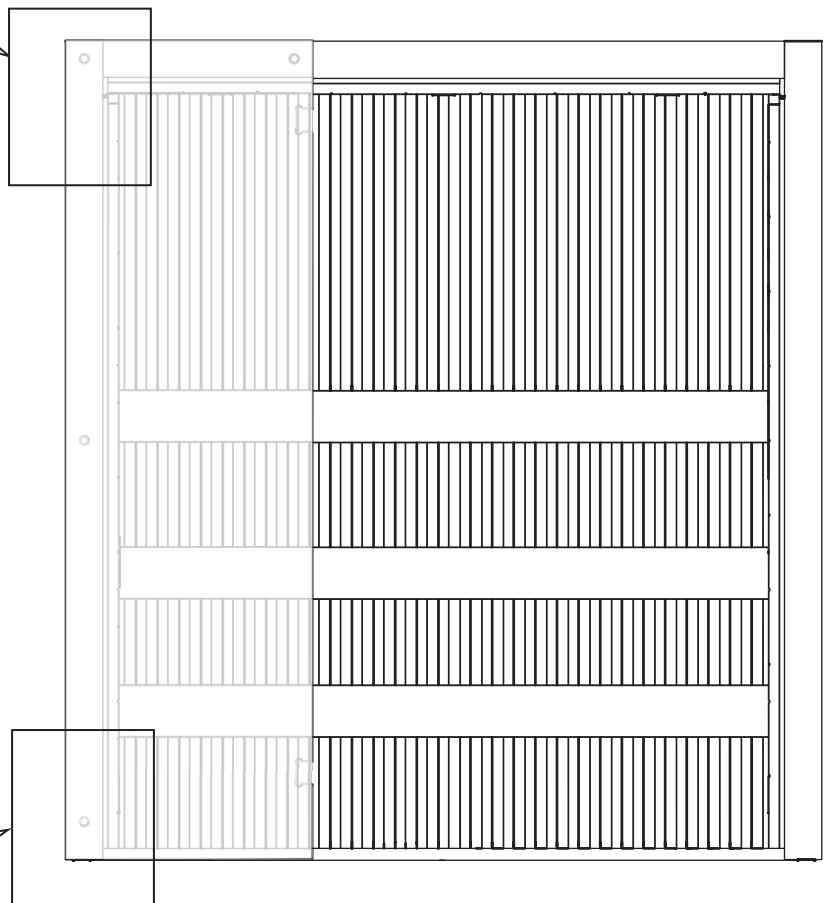

Min. 3mm

Golv / Floor

U-profil som monteras under glas kan läggas dit när glaset monteras eller skjutas in efteråt, se bild 36.

U-profile that is mounted under glass can be placed there when the glass is mounted or pushed in afterwards, see picture 36.



34

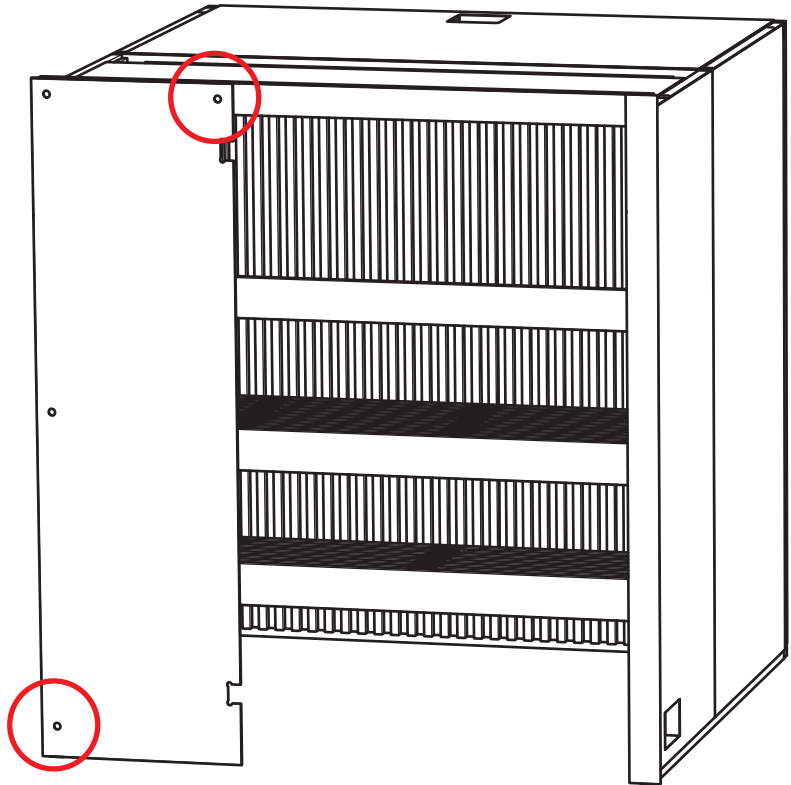
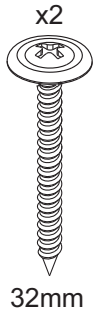
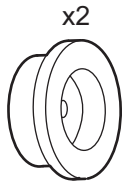

1

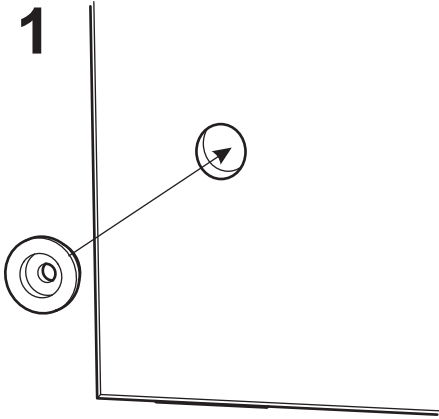

2

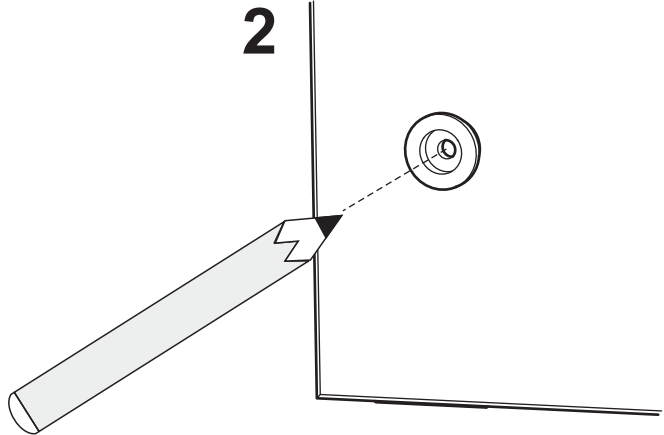

3

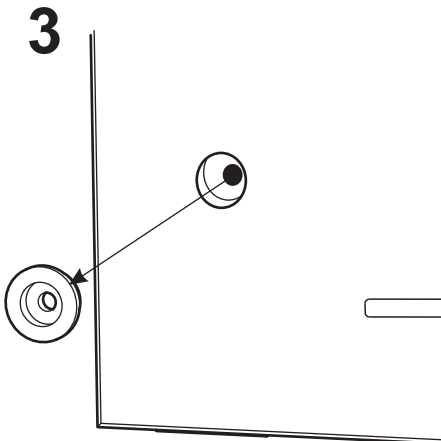

4

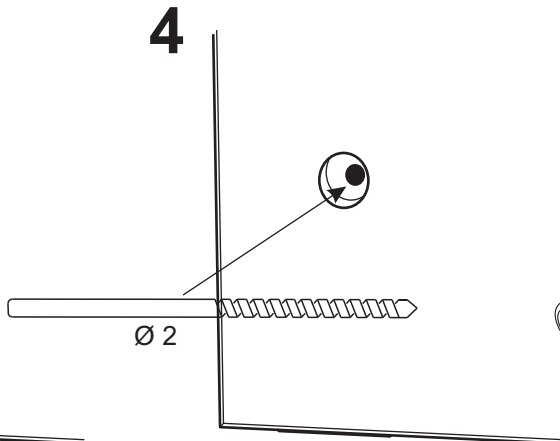

5

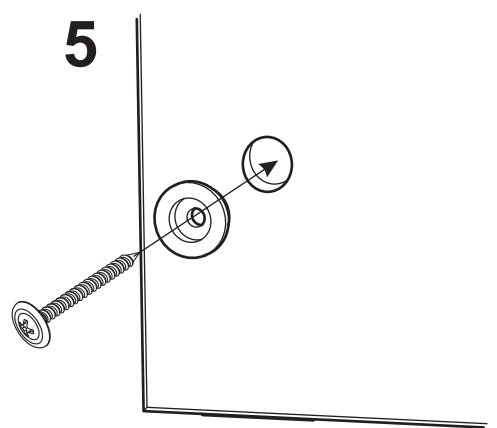

# 35

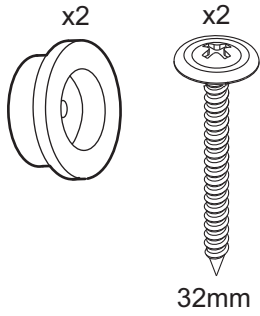

Mät mellan sidoglasen både uppe och nere så att måtten är samma. Öppningen skall vara 6mm bredare än dörrglaset. Glasen går att justera några millimeter i höjd- och sidled om man lossar lite på skruvarna.

Measure between the side glasses both top and bottom so that the measurements are the same. The opening must be 6mm wider than the door glass. The glass can be adjusted a few millimeters vertically and laterally if you loosen the screws a little.

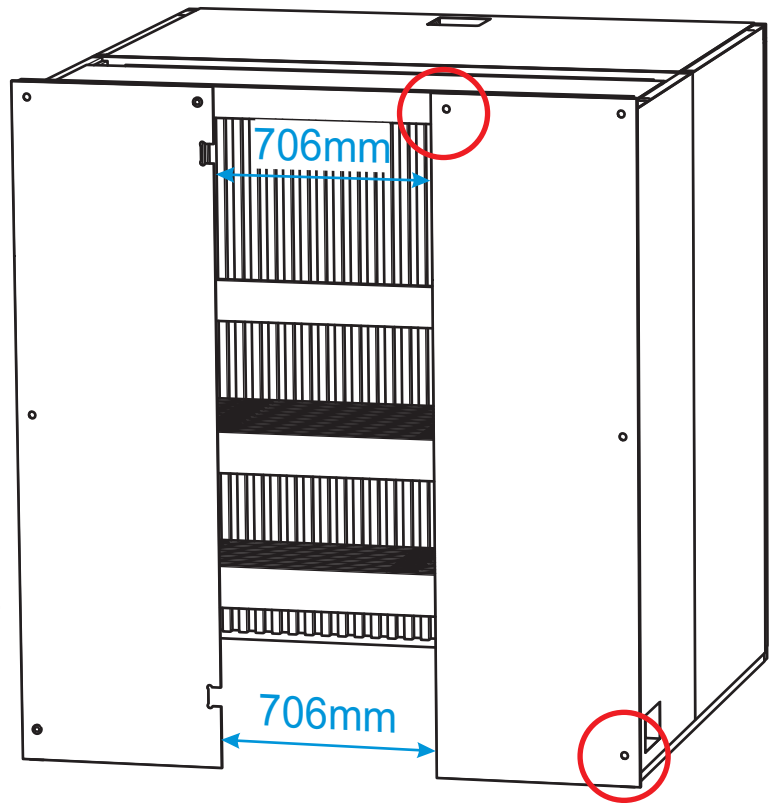

Dörrglas 700mm - öppning 706mm.  
Door glass 700mm - opening 706mm.

1

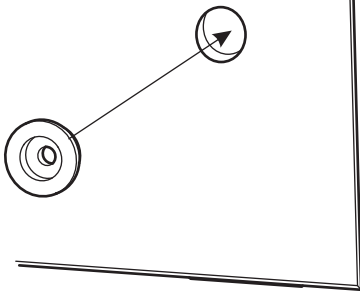

2

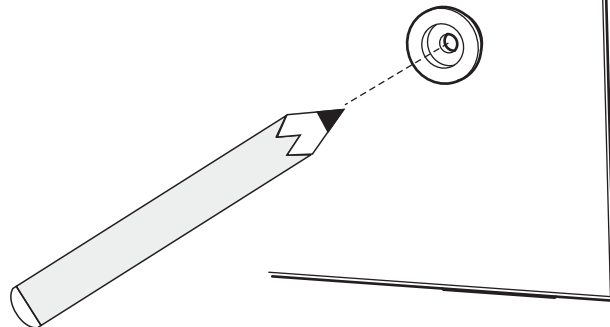

3

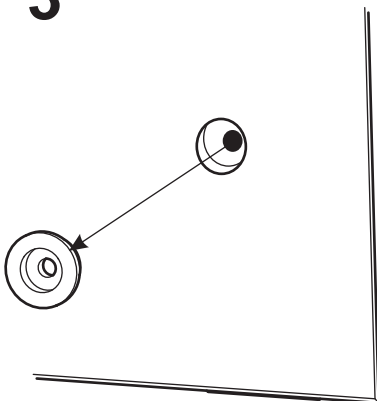

4

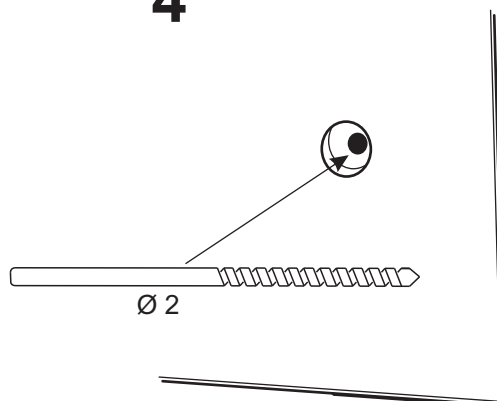

5

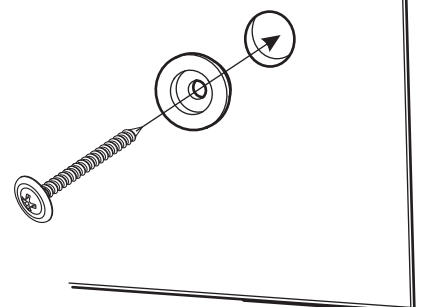

# 36

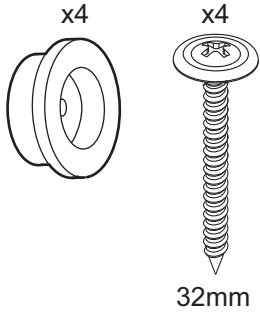

Gör om steg 1-5 på föregående sida.

Repeat steps 1-5 on the previous page.

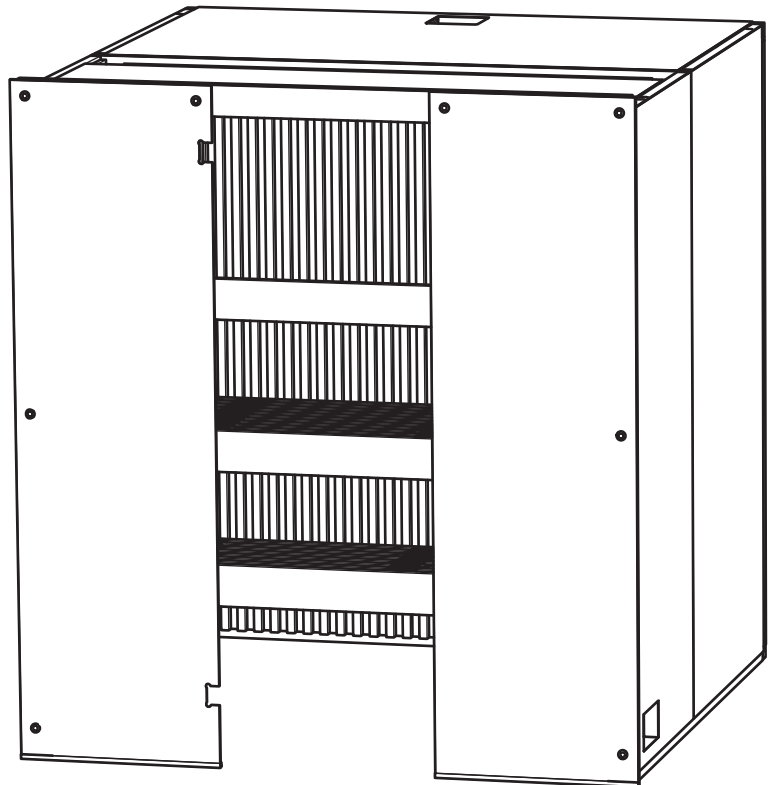
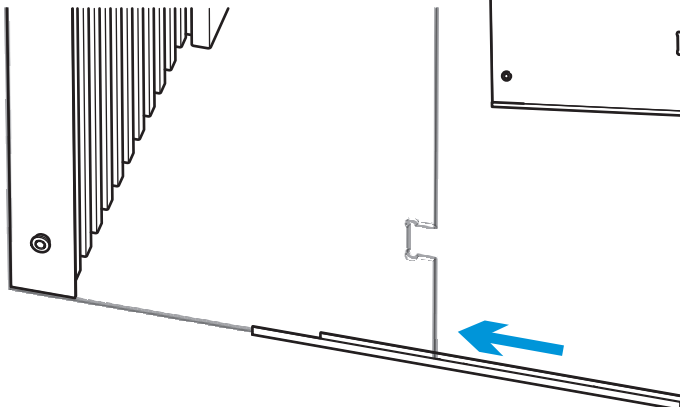
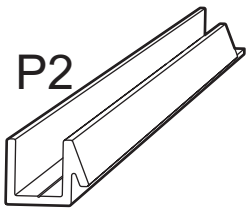
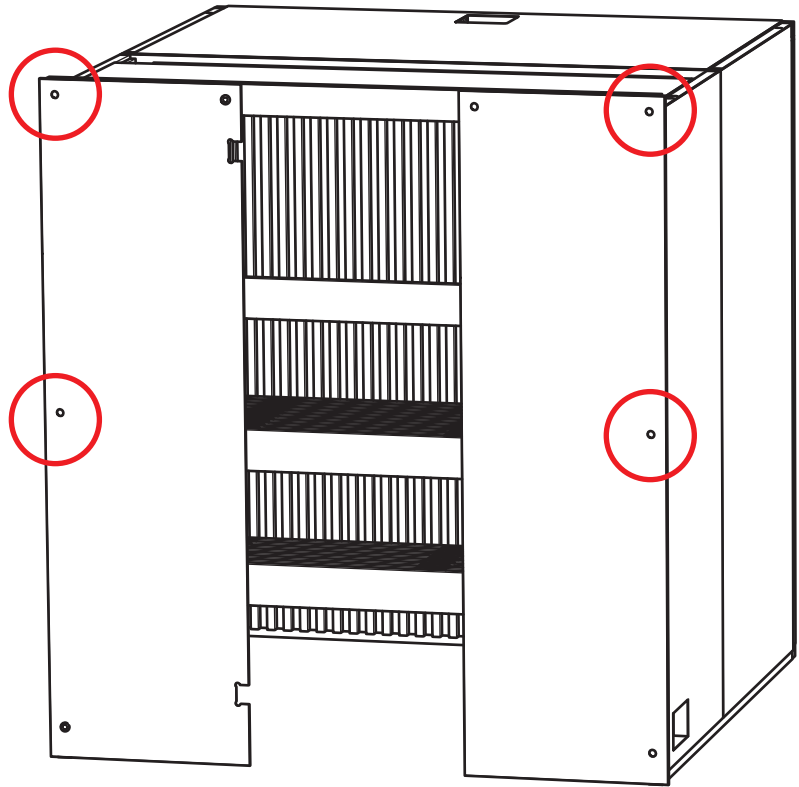

# 37 GÅNGJÄRN GLAS-GLAS HINGES GLASS-GLASS

Montera gångjärnen på sidoglasets.

Mount the hinges on the side glass

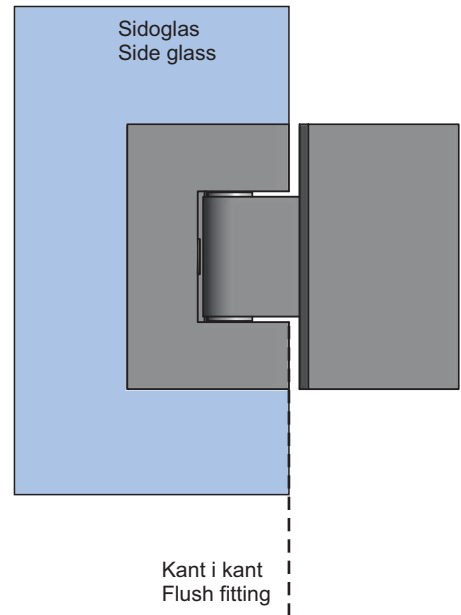
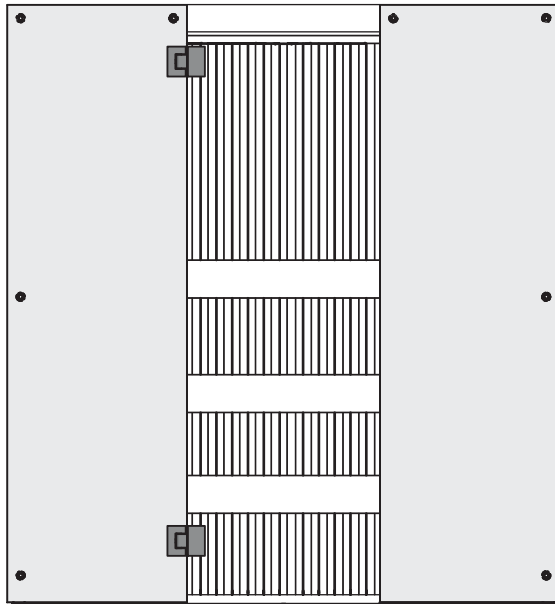

Insida  
Inside

Utsida  
Outside

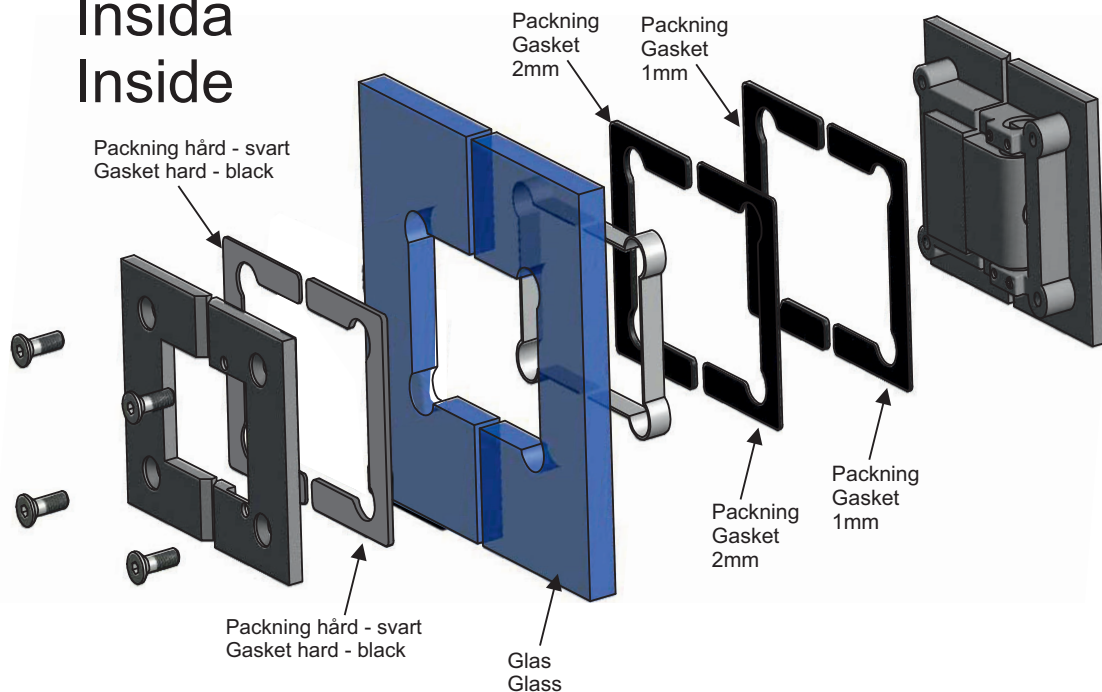

Lägg till fler packningar vid behov för att säkerställa att skruvarna drar fast tillräckligt.

Add more gaskets if necessary to make sure that the screws tighten enough.

38

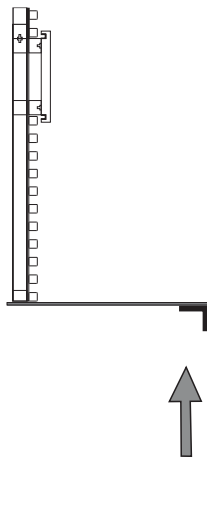

Dörrglas  
Door glass

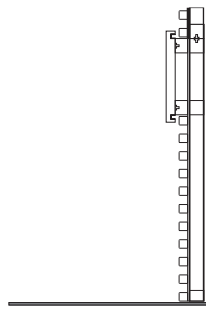

Tip!  
Distanser  
Höjd ca: 16mm

Tip!  
Distance block  
Height ca: 16mm

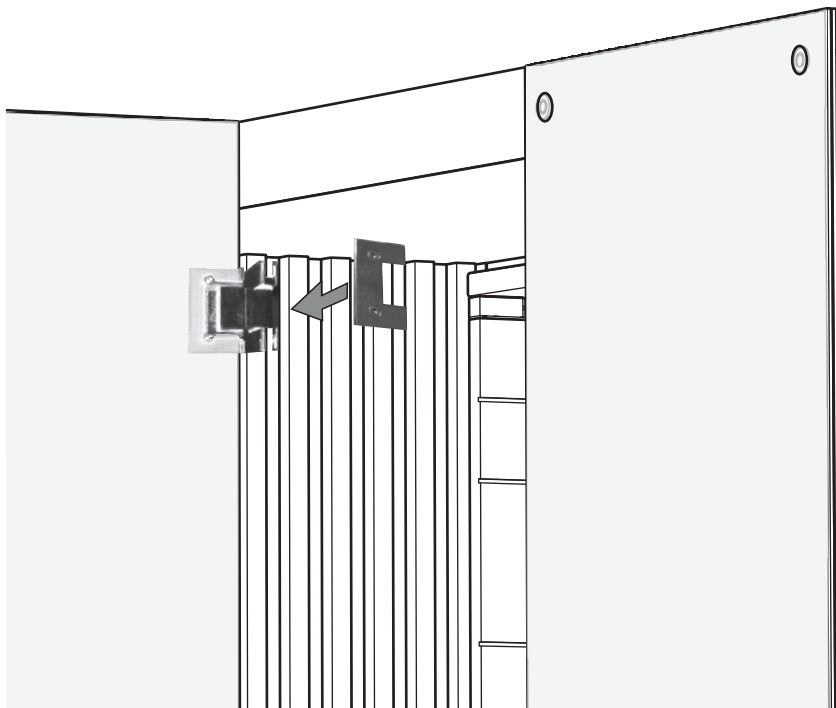
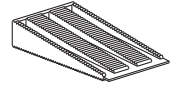

Lägg till packningar på gångjärnet  
och lyft glasdörren på plats i  
gångjärnen.  
Lägg sedan packningarna till rätta.

Add gaskets on the hinge and put  
the door glass on the hinges.  
Then put the plastic gasket into  
place.



Plastpackning  
Plastic gasket

Gångjärnen efterspännes efter cirka en vecka.  
Tighten hinge after approx. one week.

**VIKTIGT!!**

Stäng dörren sakta och säkerställ att dörrglaset inte slår i sidoglasets.

**IMPORTANT!!**

Close the door slowly and make sure the doorglass doesn't hit the side glass.

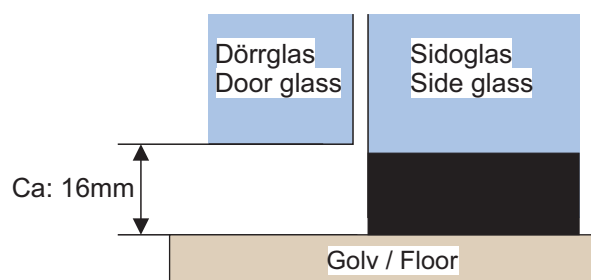

# 39 Justering gångjärn Adjust the hinges

För mer information - scanna QR-koden på kartongen till gångjärnet.

For more information - scan the QR code on the hinge box.

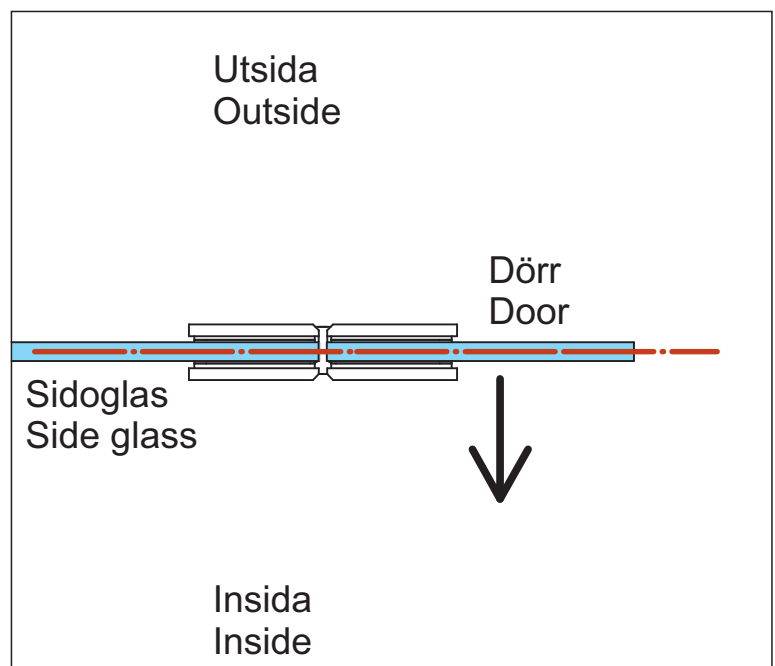
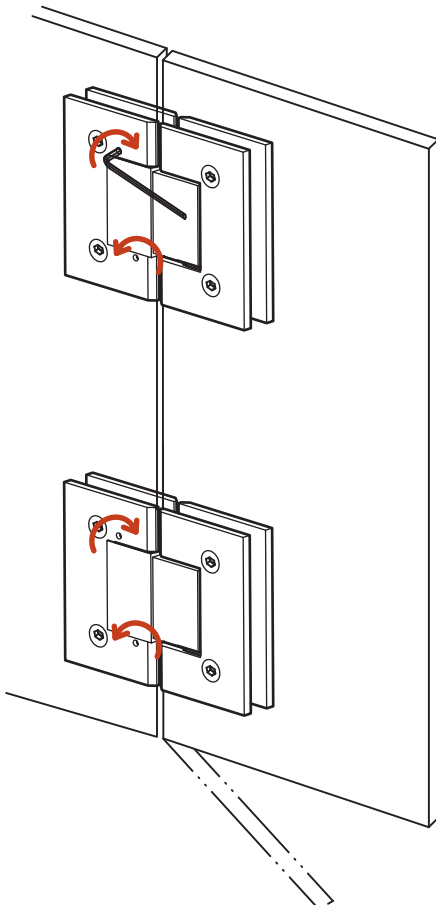
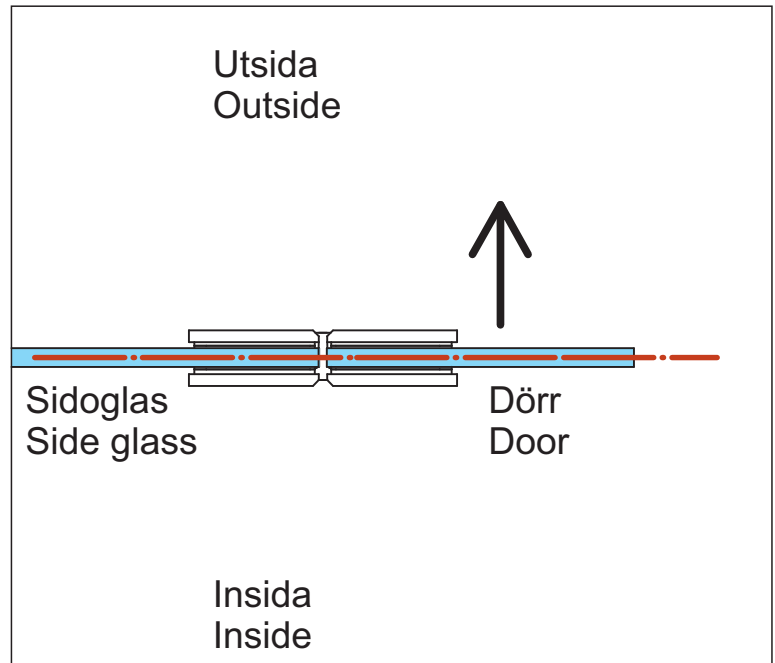
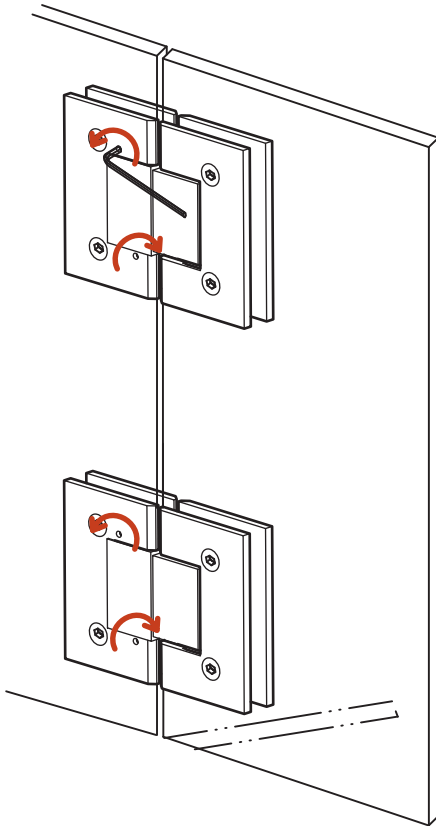

40

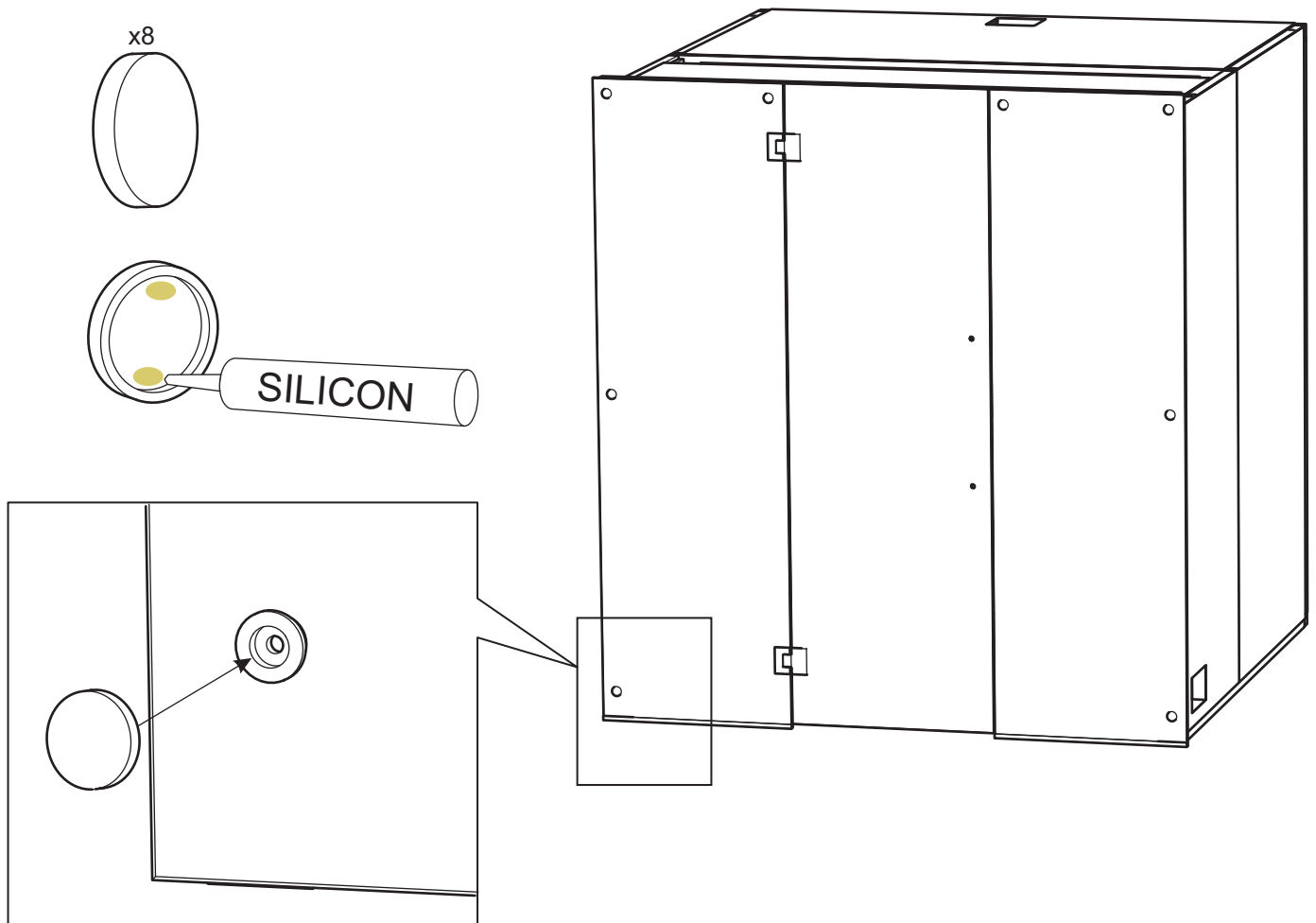
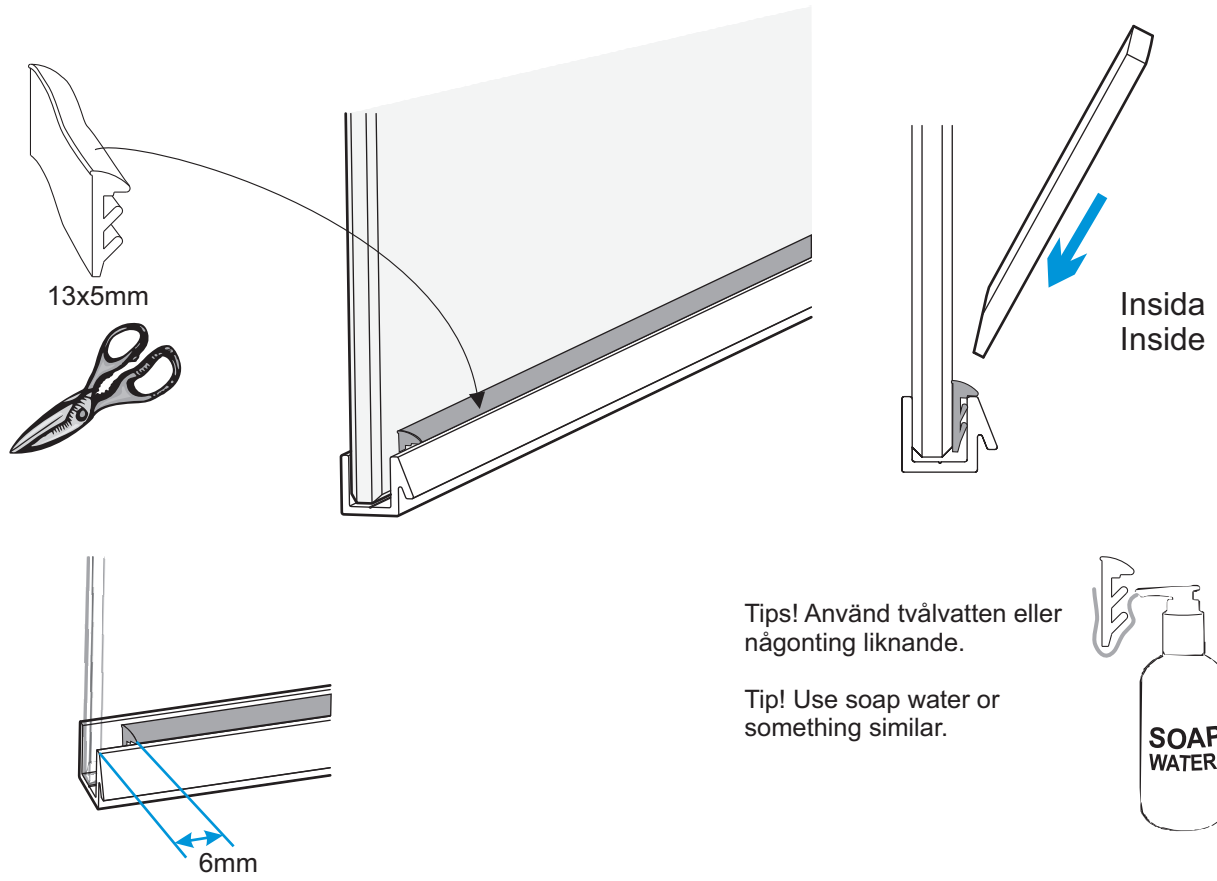

41

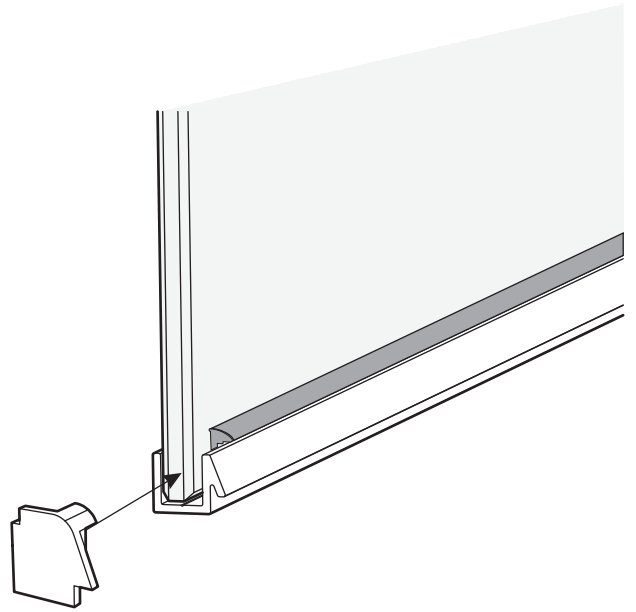
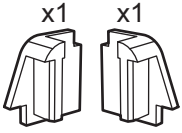

Dörrglas  
Door glass

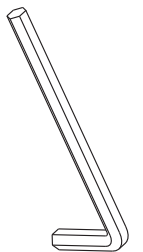
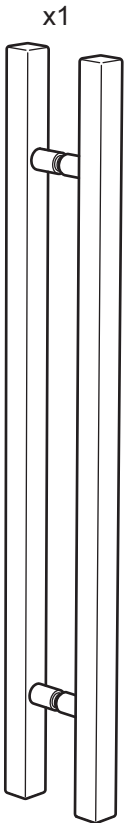

Utsida  
Outside

Insida  
Inside



42

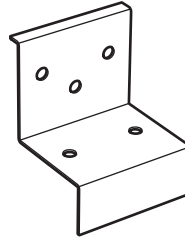
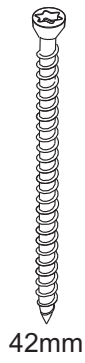
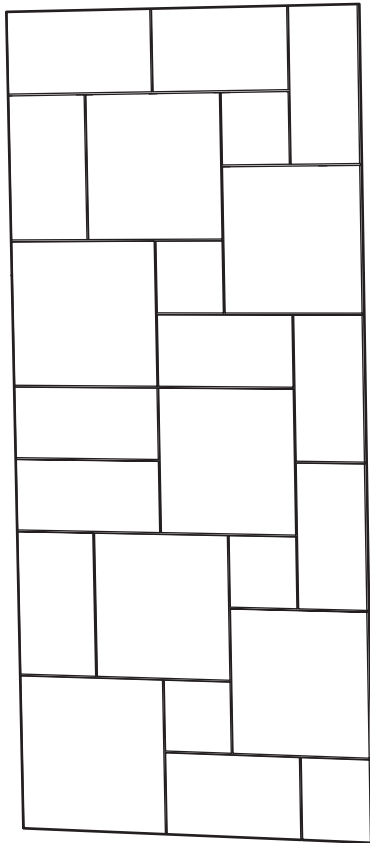

Ytterbeklädnaden sätts på den synliga sidan av rummet.

The exterior cladding is placed on the visible side of the room.

Vänster sida synlig  
Left side visible

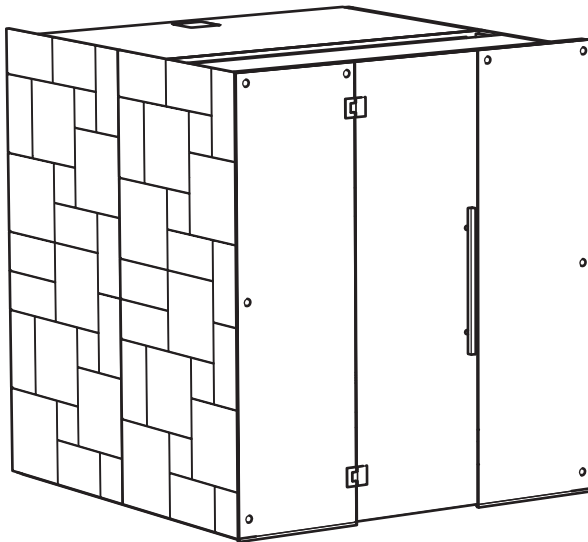

Höger sida synlig  
Right side visible

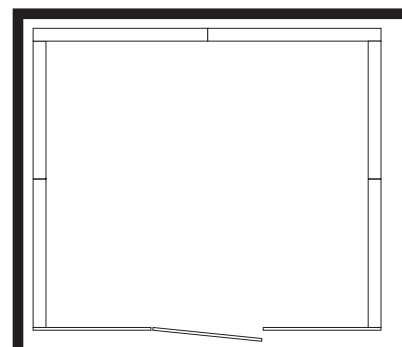
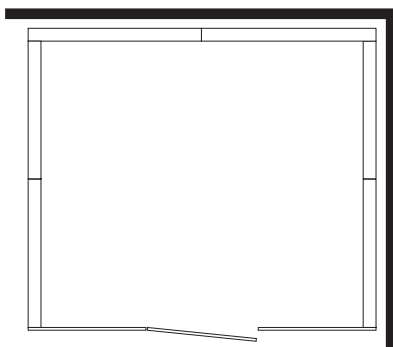
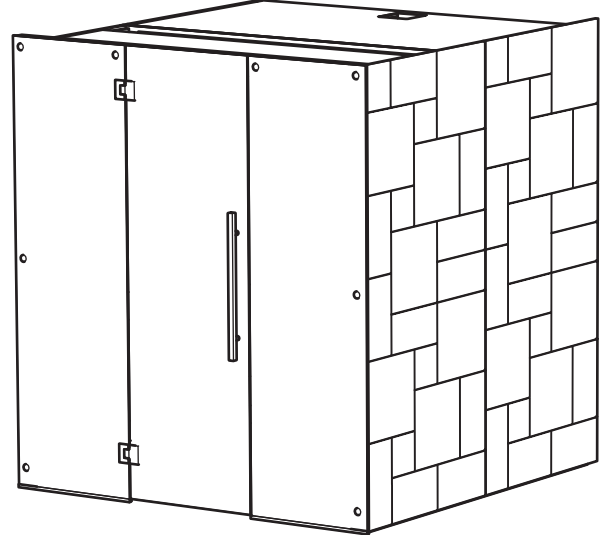

# 43

Oavsett vilken sida av rummet ytterbeklädnaden skall sitta så sätts skivan med spår längs hela kanten mot fronten.

Regardless of which side of the room the exterior cladding is to be on, the board with a groove along the entire edge is placed towards the front

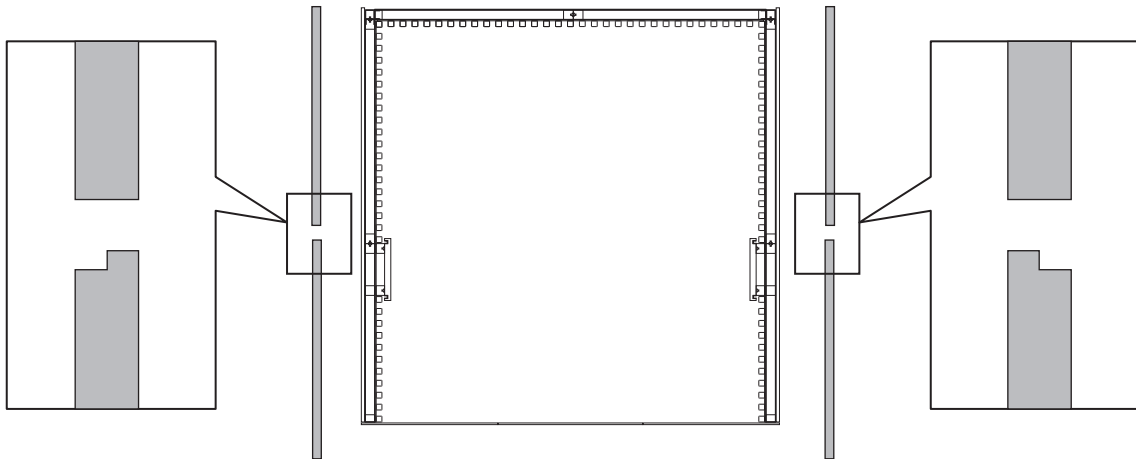

Ställ den främre skivan mot väggen i kant med fronten  
Place the front panel against the wall flush with the front

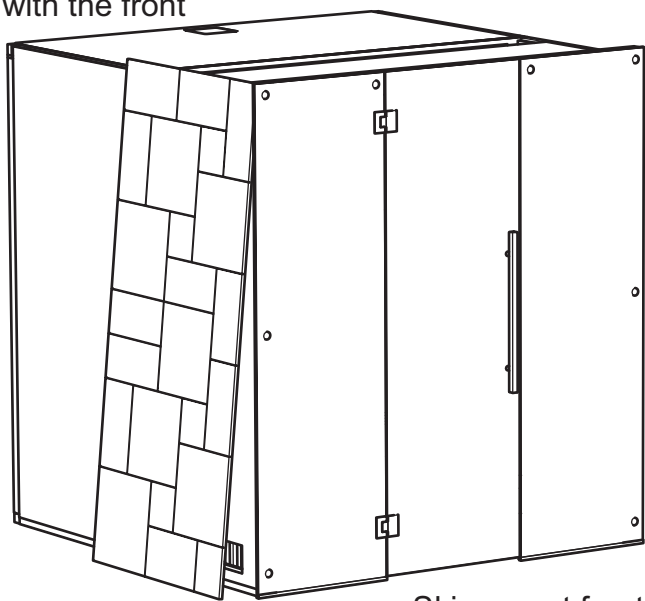

Monteringsblecken ska skruvas fast i skivan och sedan hängas över taket. Rita på ovankanten på skivan var monteringsblecken skall sitta så att det finns plats i spåret mellan reglarna på taket.

The mounting plate must be screwed into the panel and then hung over the ceiling. Draw on the top edge of the panel where the mounting plate should be placed so that there is room in the groove between the studs on the ceiling.

Skivan mot fronten  
Panel against the front

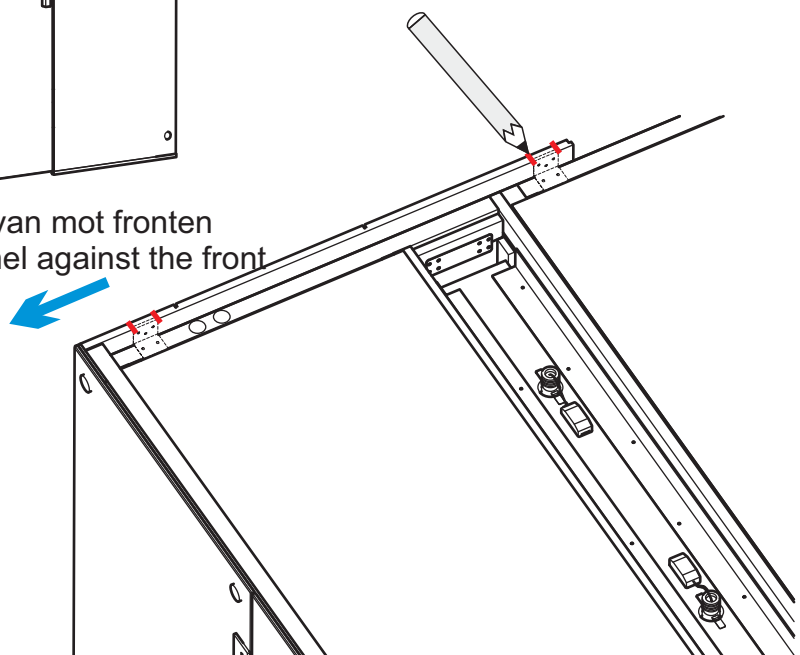
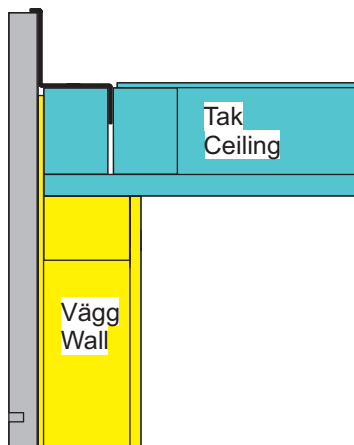

44

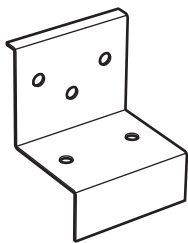

Montera blecken på ytterbeklädnaden  
Mount the plates on the exterior cladding

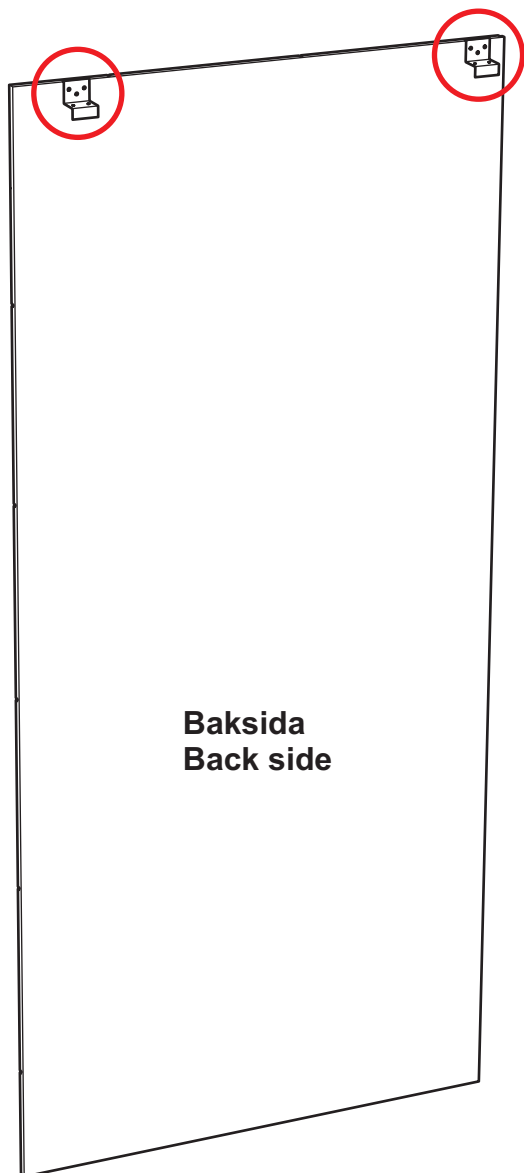

**Baksida**  
**Back side**

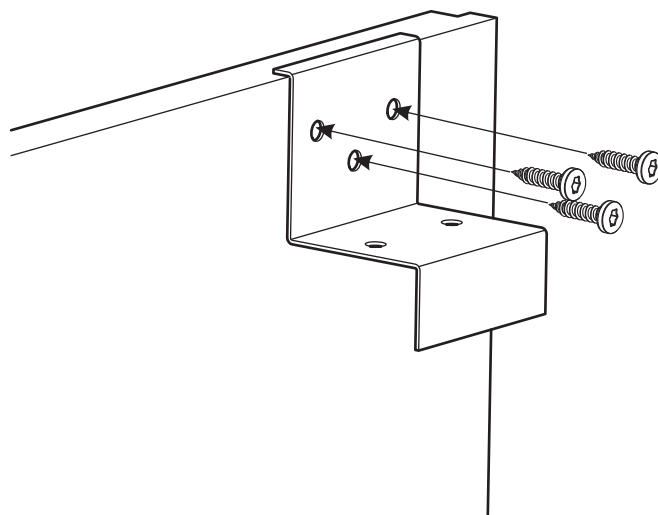

# 45

Häng ytterbeklädningen på plats.

Hang the exterior cladding in place.

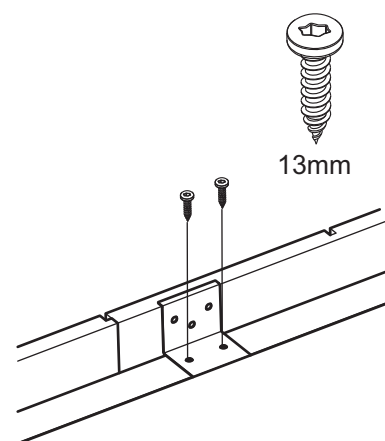
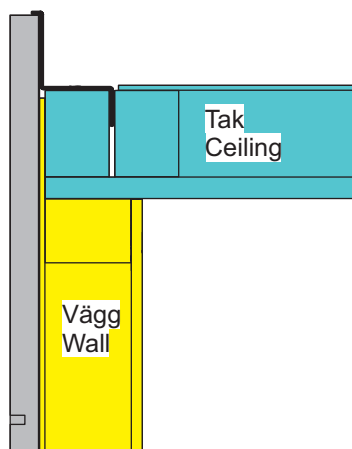
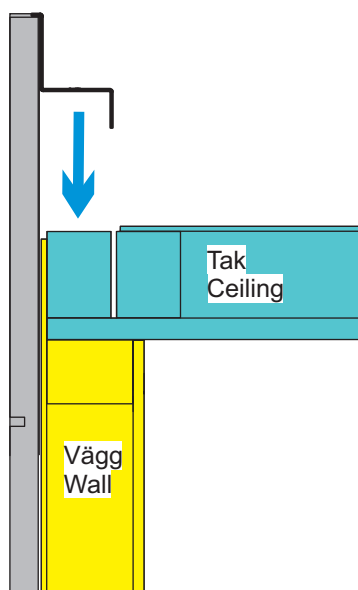
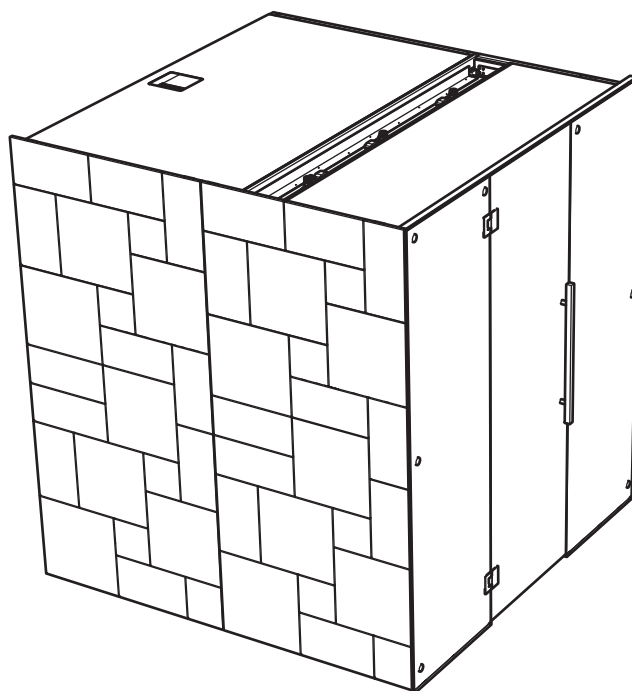

46

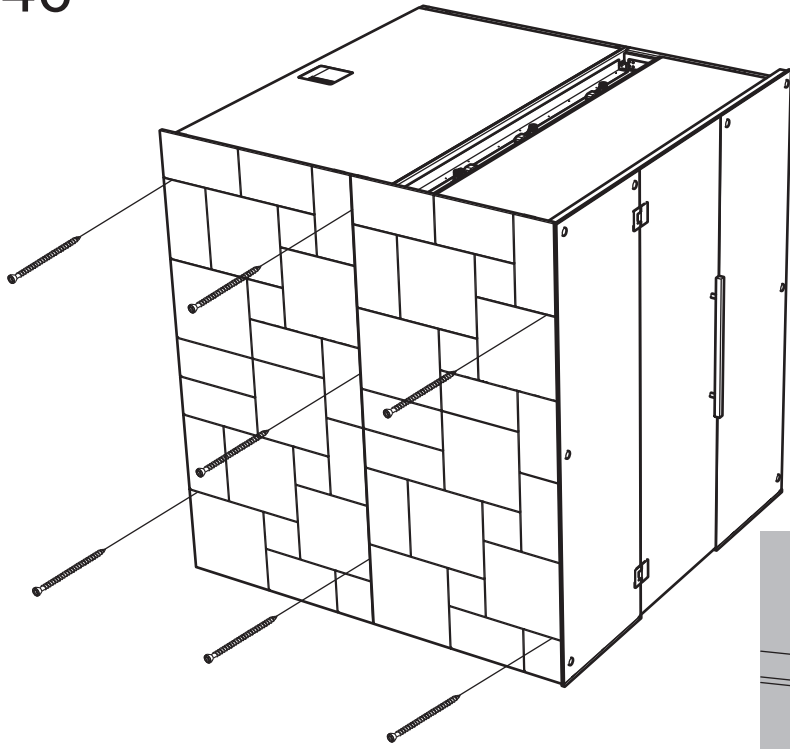

42mm

Skruva fast med några skruv i spåren på ytterbeklädnaden. Se till att skruven hamnar i en träregel, se ritning.

Fasten with a few screws in the traces of the exterior cladding. Make sure that the screw ends up in a wooden plank, see drawing.

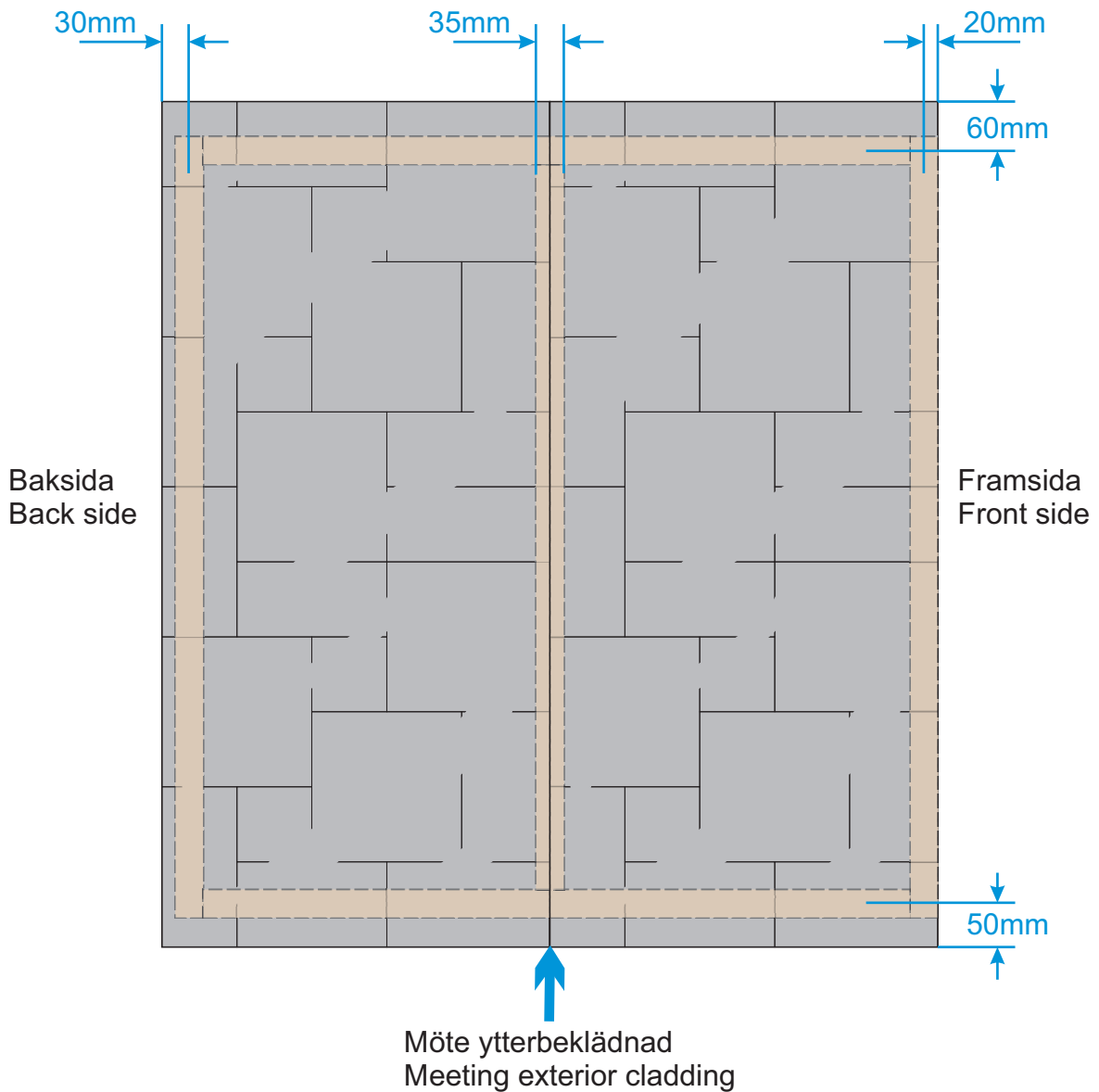
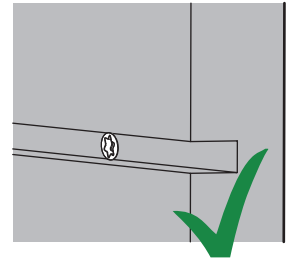
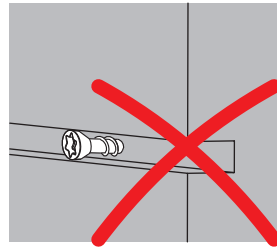

47

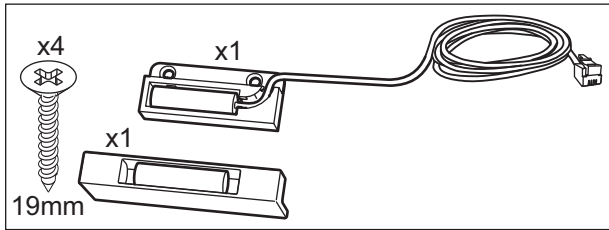

Montera dörrkontakten  
Mount the door contact

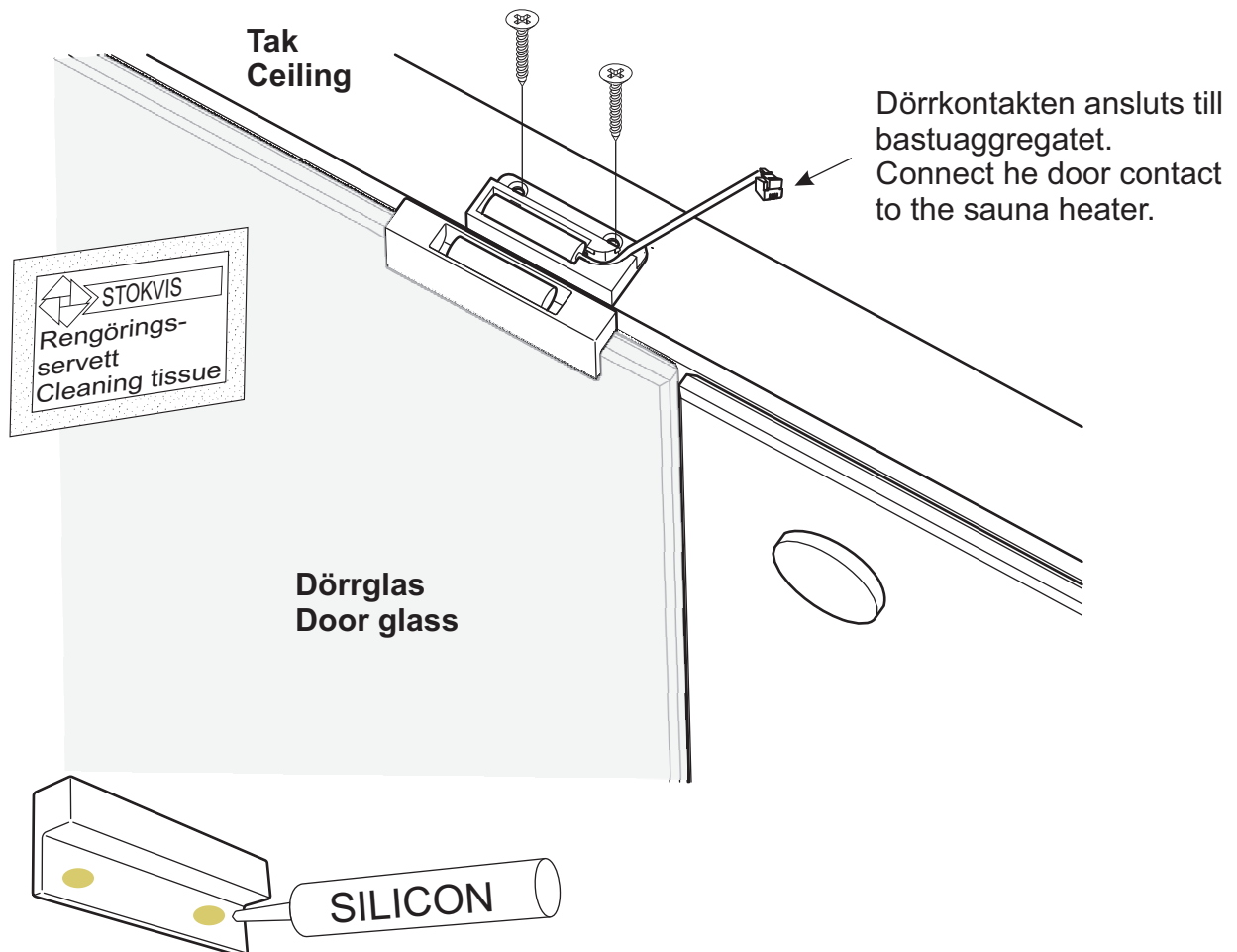
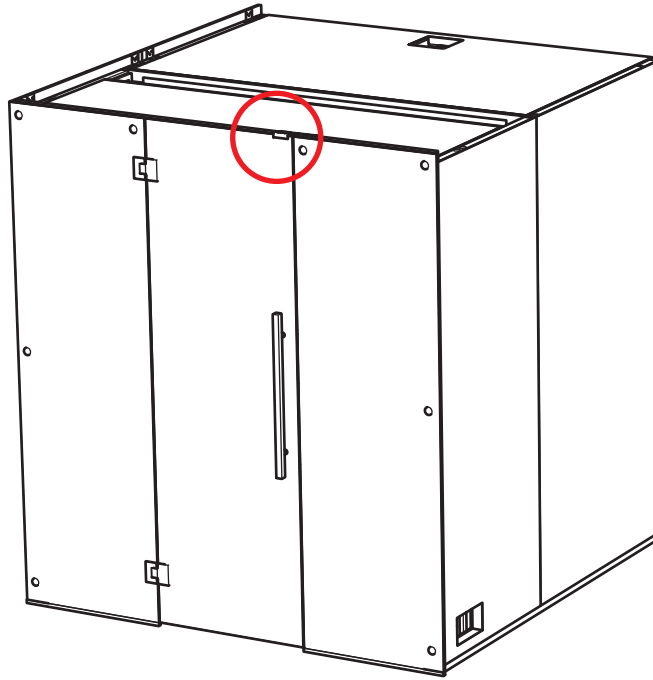

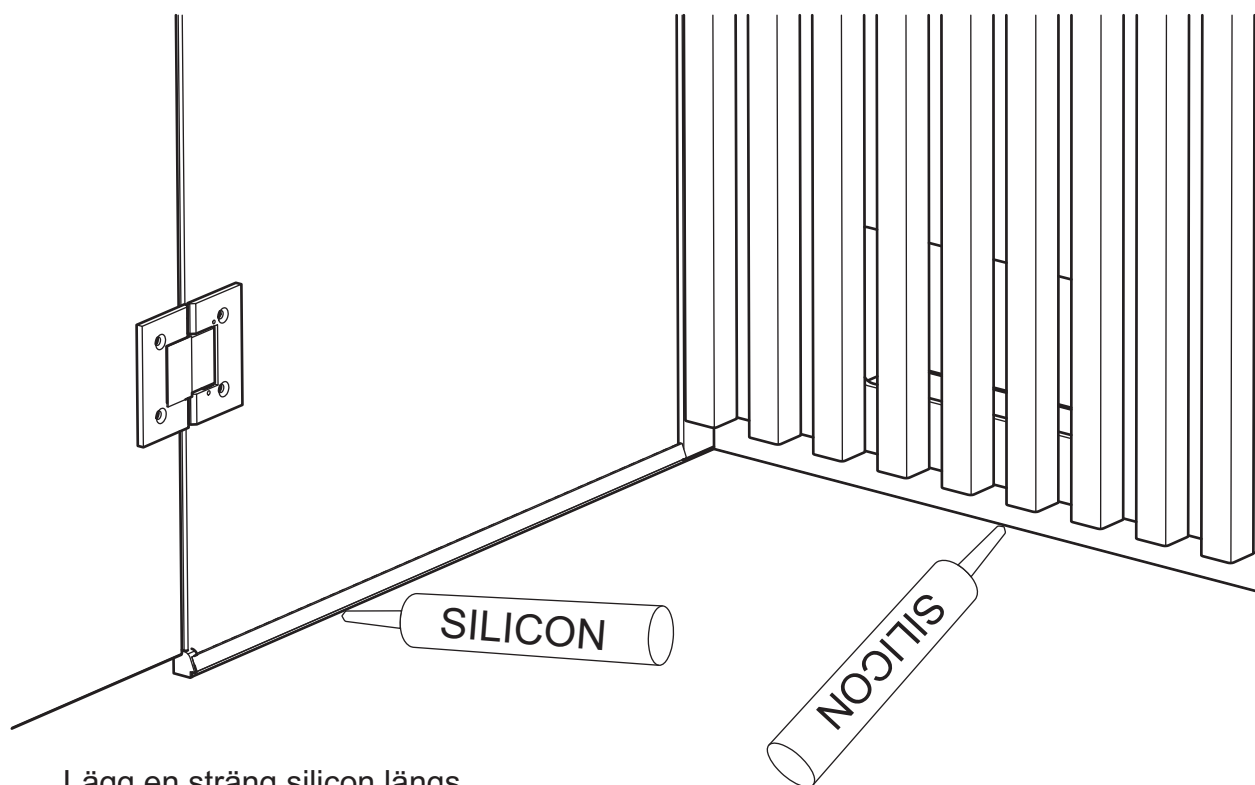

Lägg en sträng silikon längs  
golvransprofilerna.  
Put a string of silicon along the floor  
profiles.

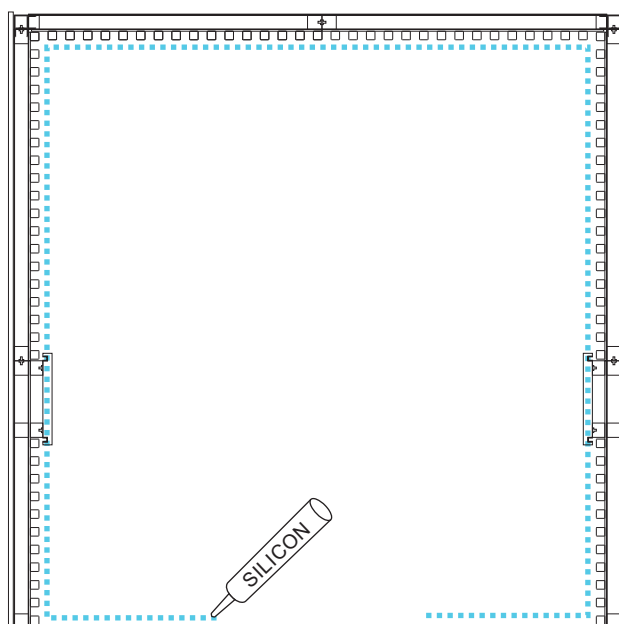

# 49

Placera Trafoplåten ovanpå takportalen  
Place the transformer plate on the ceiling portal

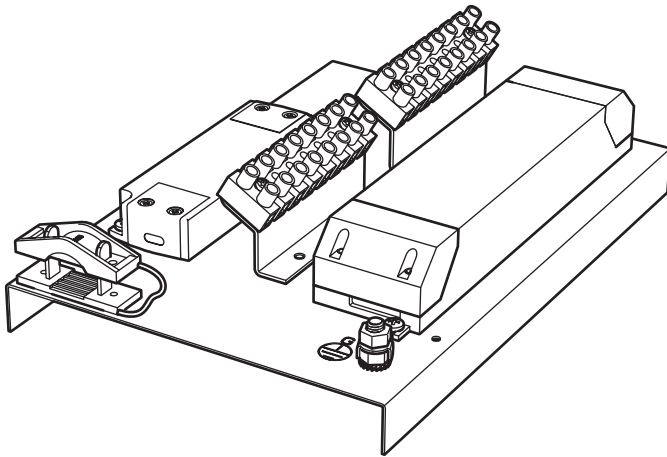
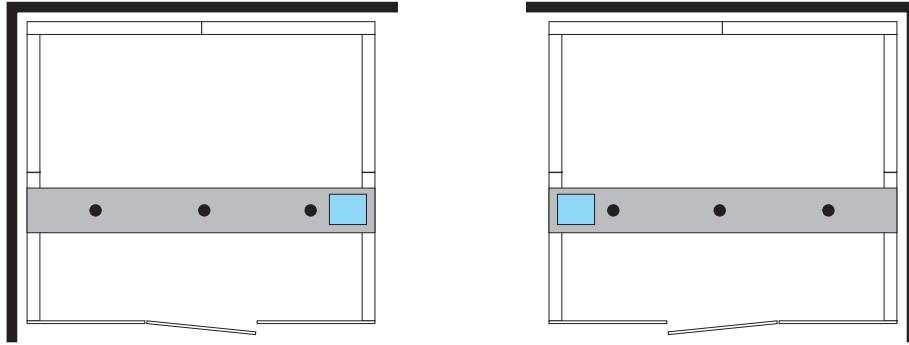

Elektrisk installation  
Electrical installation

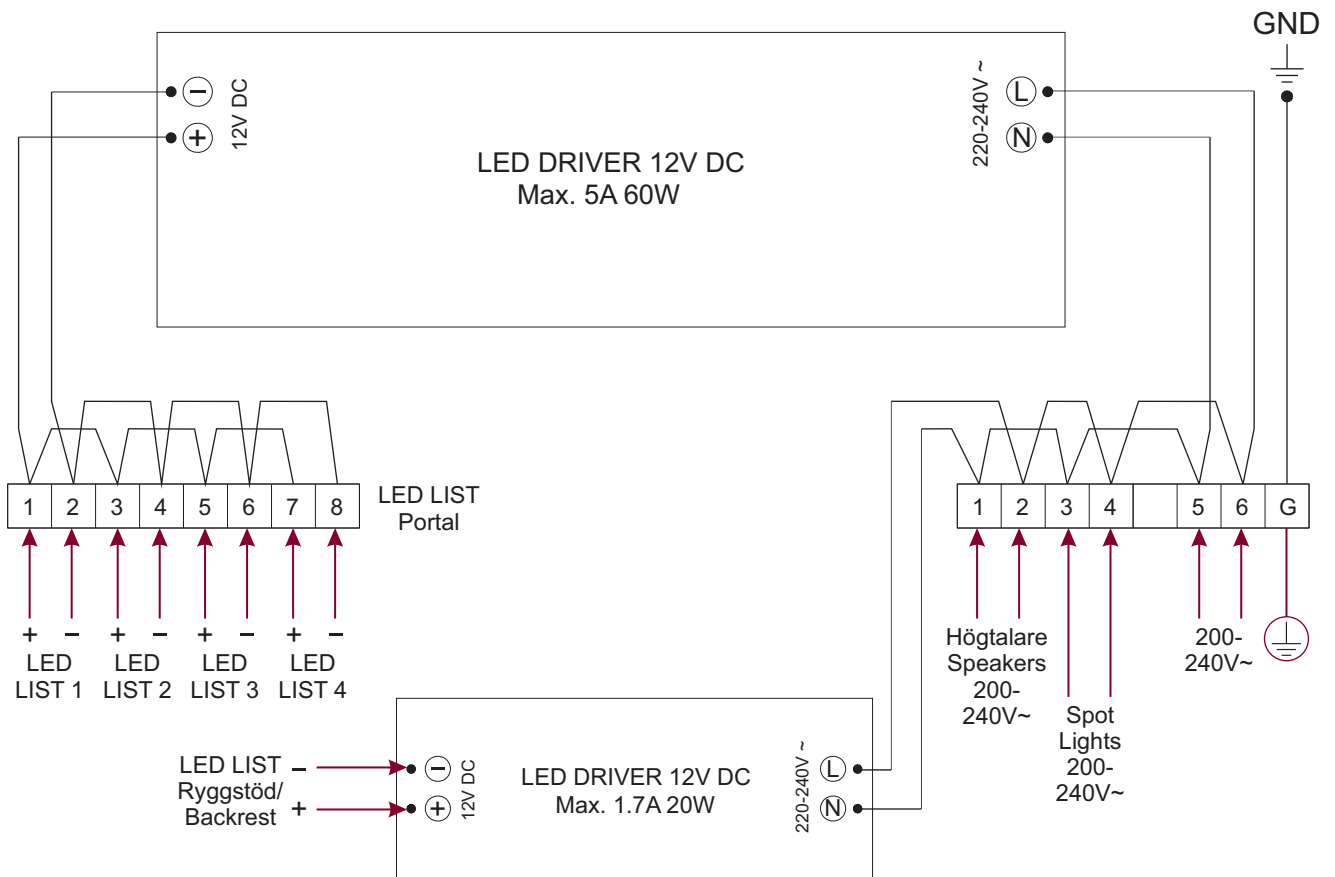



50

Hål ovanför trafoplåten  
Holes above the transformer plate

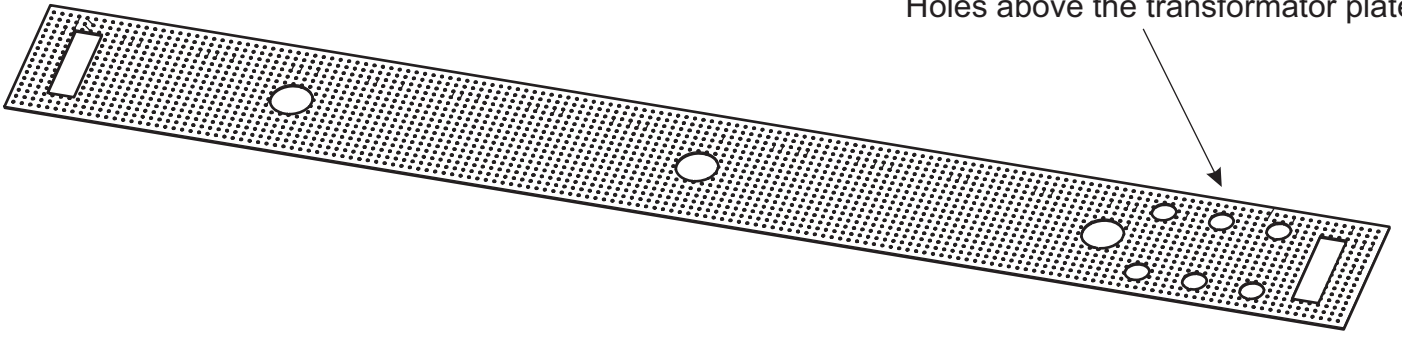

Lägg vent.skivan på plats  
Put the ventilation board in place

